

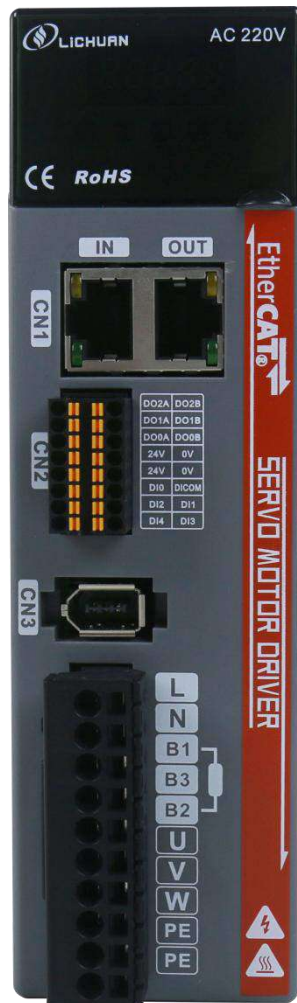

A5-E series AC Servo Driver

EtherCAT Communication User Manual



Shenzhen Xinlichuan Electric Co., Ltd.

catalog

Chapter 1 Safety Precautions	1
Chapter 2 Electrical Specifications	1
2.1 Specifications	1
2.2 Driver Model	2
Chapter 3 Installation	3
3.1 Installation of servo drive unit	3
3.1.1 Installation environment.....	3
3.1.2 Installation instructions.....	3
3.1.3 Installation Size.....	4
3.2 Installation of servo motor	4
3.2.1 Installation environment.....	4
3.2.2 Installation.....	4
Chapter 4 Wiring	5
4.1 Terminal Description	5
4.2 Main circuit wiring	6
4.2.1 Definition of Main Circuit Terminals.....	6
4.2.2 Main circuit power terminal (spring type) usage method.....	6
4.2.3 Driver wiring diagram.....	7
4.3 Definition of Wiring Terminals	8
4.3.2 Control Terminal Definition (CN2).....	8
4.3.3 Encoder Terminal Definition (CN3).....	8
4.3.4 Definition of Communication Terminals (CN4/CN5).....	9
4.4 Control signal terminal wiring	10
4.4.1 DI input circuit.....	10
4.4.2 DO output circuit.....	10
4.5 Detailed Description of DI/DO Port Function Configuration	11
4.5.1 DI Function Description.....	11
4.5.2 DO Function Description.....	11
Chapter 5 Panel Display and Operation	12
5.1 Panel Introduction and Explanation	12
5.1.1 Panel Button Description.....	12
5.1.2 Panel button operation method.....	12
5.1.3 Parameter number display.....	12
5.1.4 Status display.....	13
5.1.5 Parameter value display.....	13
5.1.6 Monitoring parameter display (P0B group parameters).....	14
5.2 Common operations	15
5.2.1 Initialize parameters.....	15
5.2.2 Manual reset alarm.....	15
5.2.3 JOG mode operation.....	16
5.3 Gain parameter settings and instructions	16
Chapter 6 Communication Network Configuration	17
6.1 EtherCAT networking diagram	17
6.1.1 EtherCAT communication technology specifications.....	17
6.2 Driver related parameter configuration	18
6.2.1 system parameter setting.....	18

6.2.2 Rotation direction selection.....	18
6.2.3 Holding brake setting.....	18
6.3 Communication cycle of each mode.....	19
6.4 Process Data PDO.....	19
6.4.1 Variable PDO mapping.....	19
6.4.2 Fixed PDO mapping.....	19
Chapter 7 Control Mode Description.....	21
7.1 Introduction to Control.....	21
6.5.1 Control word 6040h.....	22
6.5.2 Status word 6041h.....	22
7.2 Working mode.....	23
7.2.1 Introduction to servo mode.....	23
7.2.2 Servo mode switching.....	23
7.3 Periodic synchronous position mode (CSP mode).....	23
7.4 Periodic synchronous speed mode (CSV mode).....	24
7.5 Periodic synchronous torque mode (CST mode).....	25
7.6 Profile position mode (PP mode).....	26
7.7 Profile speed mode (PV mode).....	27
7.8 Contour torque mode (PT mode).....	28
7.9 Zero return mode (HOME mode).....	29
7.10 Probe Function Description.....	30
7.10.1 Function Description of 60B8h and 60B9h.....	30
7.10.2 Read the probe latch position.....	31
Chapter 8 Parameter Description.....	32
8.1 1000 sets of object dictionary parameters.....	32
8.2 2000 sets of object dictionary parameters.....	32
8.2.1 2001 Group Object Dictionary (P01 Group Parameters).....	32
8.2.2 2002 Group Object Dictionary (P02 Group Parameters).....	33
8.2.3 2003 Group Object Dictionary (P03 Group Parameters).....	33
8.2.4 2004 Group Object Dictionary (P04 Group Parameters).....	34
8.2.5 2005 Group Object Dictionary (P05 Group Parameters).....	34
8.2.6 2006 Group Object Dictionary (P06 Group Parameters).....	35
8.2.7 2007 Group Object Dictionary (P07 Group Torque Control Parameters).....	35
8.2.8 2008 Group Object Dictionary (P08 Group Gain Class Parameters).....	36
8.2.9 2009 Group Object Dictionary (P09 Group Self Adjusting Parameters).....	37
8.2.10 200A Group Object Dictionary (P0A Group Fault and Protection Parameters).....	38
8.2.11 200B Group Object Dictionary (P0B Group Monitoring Parameters).....	39
8.2.12 200C Group Object Dictionary (P0C Group Communication Parameters).....	39
8.2.13 200D Group Object Dictionary (P0D Group Auxiliary Function Parameters).....	40
8.3 6000 sets of object dictionary parameters.....	40
Chapter 9 Fault Handling.....	43
9.1 Fault and warning code table.....	43
9.1.1 Fault Code Table (To reset the fault, disable it first).....	43
9.1.2 Warning code table (can directly reset the warning without the need to cancel the enable).....	46
Appendix 1 Shutdown Methods.....	47
Appendix 2 Servo Zero Return Method.....	48

Chapter 1 Safety Precautions

Before using the servo drive system, please carefully read the relevant precautions of the equipment, and be sure to follow the installation and debugging safety precautions and operating procedures. The company is exempt from liability for equipment damage or personal injury caused by failure to operate as required.

- ◆ This product is a general industrial product and is not intended for use with machines or systems that may affect human life
- ◆ Please have professional qualified personnel perform wiring, operation, maintenance, inspection, and other operations.
- ◆ When applied to devices that may cause major accidents or losses, please equip safety devices.
- ◆ Although this product has made every effort in quality management, unexpected factors such as noise, static electricity, input power, wiring, and parts may cause unexpected actions. Please fully consider mechanical safety measures to ensure safety with in the possible range of actions

Chapter 2 Electrical Specifications

2.1 Specification

Input power supply	Single phase 220VAC (A5-10/A5-20)	
work environment	temperature	0~45℃
	humidity	No condensation below 90% RH
	altitude	altitude ≤ 1000m
	Installation environment	No corrosive gases, flammable gases, oil mist or dust, etc
	Installation instruction	Vertical installation
Encoder	Supports 17 bit incremental/absolute encoder and 23 bit incremental/absolute encoder	
Output Voltage	24V Voltage output	100mA, Can supply power to the DI port.
Control signal	digital input	5 ordinary digital inputs, with configurable functions.
	Digital Output	3-way digital output with configurable functions.
communication	EtherCAT Communication.	
Display panel and button operation	5 buttons (Mode, Set, Left, Up, Down) and 6 digital tubes	
Regenerative discharge braking resistor	Built in 50W, 40 Ω braking resistor. Frequent braking situations require external braking resistors.	

2.2 Driver Model

<u>LCA5</u>	-	<u>10</u>	<u>E</u>	-	<u>100</u>
①		②	③		④
① : Driver series		④ : Motor power			
② : Driver power		50:50w			
10:50W~750W		100:100W			
20:1KW		200:200W			
30:1KW~2.6KW		400:400W			
50:3KW~3.8KW		750:750W			
③ : Control Type		1000:1KW			
P:Pulse type				
E:EtherCAT Bus type		3800:3.8KW			

2.3 Motor Model

<u>LCMT</u>	-	<u>02</u>	<u>LB</u>	<u>C17</u>	<u>N</u>	<u>B</u>	-	<u>60</u>	<u>M006</u>	<u>30B</u>	
①		②	③	④	⑤	⑥	⑦	⑧	⑨	⑩	
① : Motor series		⑥ : Motor brake									
② : Motor power		N:No brake									
02:0.2KW		Z:With brake									
04:0.4KW		⑦ : Motor oil seal and keyway									
.....		A: No oil seal, no keyway									
38:3.8KW		B: With oil seal, with keyway									
③ : Poles		C: Oil seal without keyway									
□: 4Poles		⑧ : Motor flange									
S: 5Poles		60:60flange									
4.Motor inertia		80:80flange									
LB:220V low inertia		130:130flange									
MB:220V Medium inertia		⑨ : Motor holding torque									
Inertia		⑩ : Motor rated power									
⑤ : Encoder Type		10: 1000RPM									
C17: 17 bit magnetic encoder incremental		15: 1500RPM									
R17: 17 bit magnetic encoder absolute value										
C23: 23 bit magnetic encoder incremental		30: 3000RPM									
R23: 23 bit magnetic encoder absolute value											

Chapter 3 Installation



- The storage and installation of the product must meet the environmental conditions requirements.
- Damaged or incomplete products shall not be installed or used.
- The installation of the product requires fireproof materials and should not be installed on or near flammable materials to prevent fires.
- The servo drive unit must be installed inside the electrical cabinet to prevent dust, corrosive gases, conductive objects, liquids, and flammable substances from entering.
- The servo drive unit and servo motor should avoid vibration and be prohibited from bearing impacts.
- It is strictly prohibited to drag the servo motor wires and encoder wires

3.1 Installation of servo drive unit



- The servo drive unit must be installed in a well protected electrical cabinet.
- The servo drive unit must be installed in the specified direction and interval, and ensure good heat dissipation conditions.
- Do not install on or near flammable objects to prevent fires.

3.1.1 Installation Environment

- ◆ Temperature/humidity: 0-55 °C (without frost), below 90% RH (without condensation).
- ◆ Storage temperature/humidity: -20~65 °C (without frost), below 90% RH (without condensation).
- ◆ Atmospheric environment: inside the control cabinet, without corrosive, flammable gases, oil mist, dust, etc.
- ◆ Elevation: Below 1000m above sea level.
- ◆ Vibration: less than 0.5G (4.9m/s²), 10-60 Hz (non continuous operation)
- ◆ Protection: The servo drive itself has no protective structure, so it must be installed in a well protected electrical cabinet to prevent corrosive, flammable gases, and conductivity, intrusion of objects, metal dust, oil mist, and liquids.

3.1.2 Installation Intruction

- ◆ Our company's servo drive is a vertical structure, please install it vertically. The installation direction is perpendicular to the installation face upwards.
- ◆ The installation layout of a single or multiple servo drives is shown in the following figure.

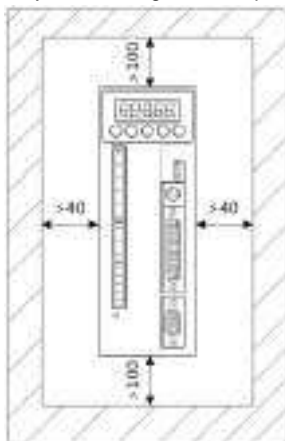

Installation interval of single servo drive unit

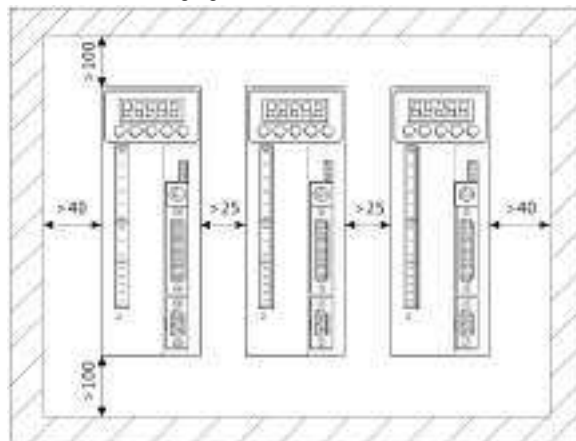

Installation interval for multiple servo units

3.1.3 Installation dimensions

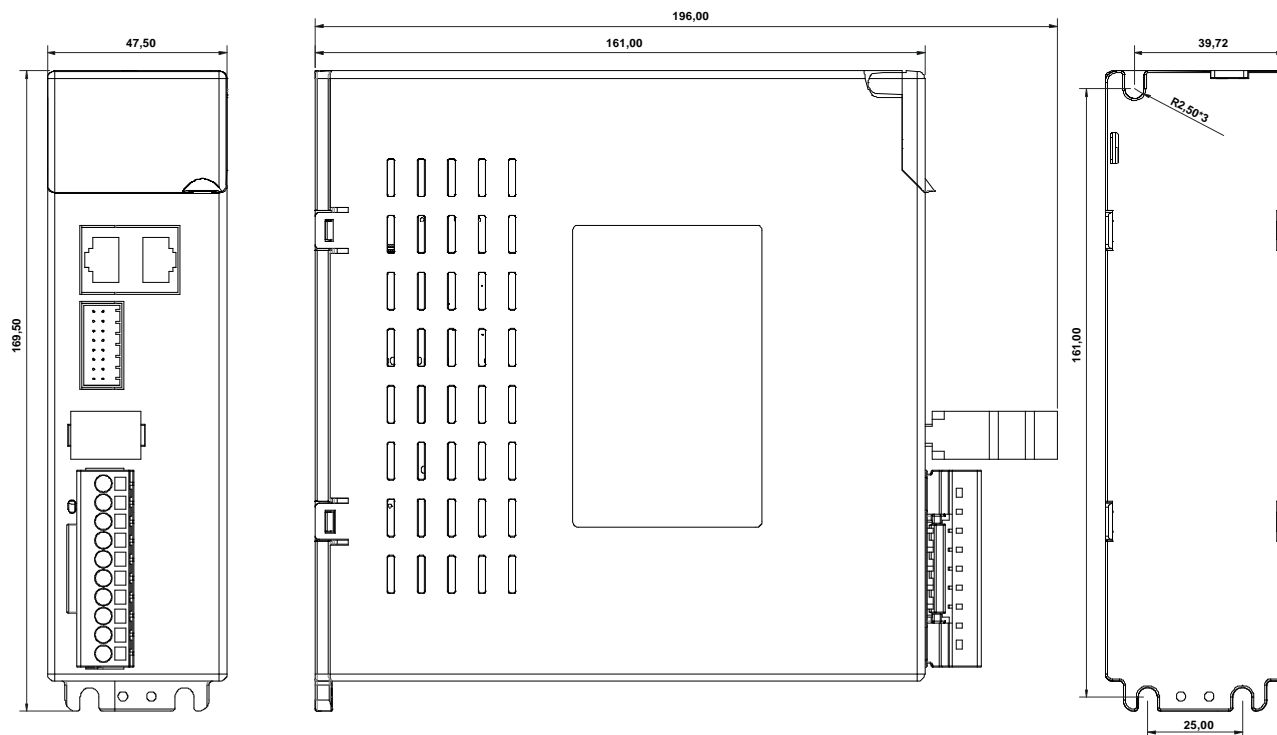

A5-10E/A5-20E Driver Dimensions

3.2 Installation of servo motor

 Warn

● It is strictly prohibited to strike the shaft end of the motor, otherwise it may damage the motor encoder.

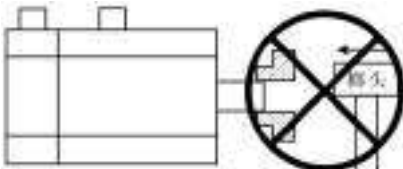

3.2.1 Installation Environment

- ◆ Using temperature/humidity: 5~40℃ (no frost), below 90%RH (no condensation).
- ◆ Storage temperature/humidity: -20~55℃ (no frost), below 80%RH (no condensation).
- ◆ Atmospheric environment: Indoor (no exposure), no corrosive, flammable gas, oil mist, dust, etc.
- ◆ Elevation: below 1000m above sea level.
- ◆ Vibration: less than 0.5G (4.9m/s²), 10~60 Hz (non-continuous operation).
- ◆ Protection level: IP54

3.2.2 Installation Intruction

- ◆ Installation direction: To prevent liquids such as water and oil from flowing into the motor from the motor outlet, please place the cable outlet below. If the motor shaft is installed facing upwards and
When a gearbox is attached, it is necessary to prevent oil stains inside the gearbox from seeping into the motor shaft.
- ◆ Concentric: When connecting with machinery, please use a coupling device and keep the axis of the servo motor in a straight line with the axis of the machinery .
- ◆ Cable: Do not bend or apply tension to the cable, so when wiring (using), please do not tension the cable too tightly.
- ◆ Fixed: The motor installation must be firm and equipped with anti loosening measures.

Chapter 4 Wiring



- The power supply for this series of drives is single-phase 220V, and it is necessary to check the power supply used by the drive when wiring.
- Users must consider safety precautions during the design and assembly of this product to prevent accidents caused by incorrect operations
- The drive terminals U, V, and W must correspond to the motor U, V, and W, otherwise it may cause speeding.
- The driver and motor must be well grounded.
- Before disassembling this drive, it must be powered off for at least 5 minutes.
- Frequent power on/off is prohibited. After a power outage, it is necessary to wait for the digital tube to turn off before reconnecting.
- When using internal braking resistors, the short circuit must be connected between terminals B2 and B3, and it is prohibited to directly connect wires between B1 and B2.

4.1 Terminal Description

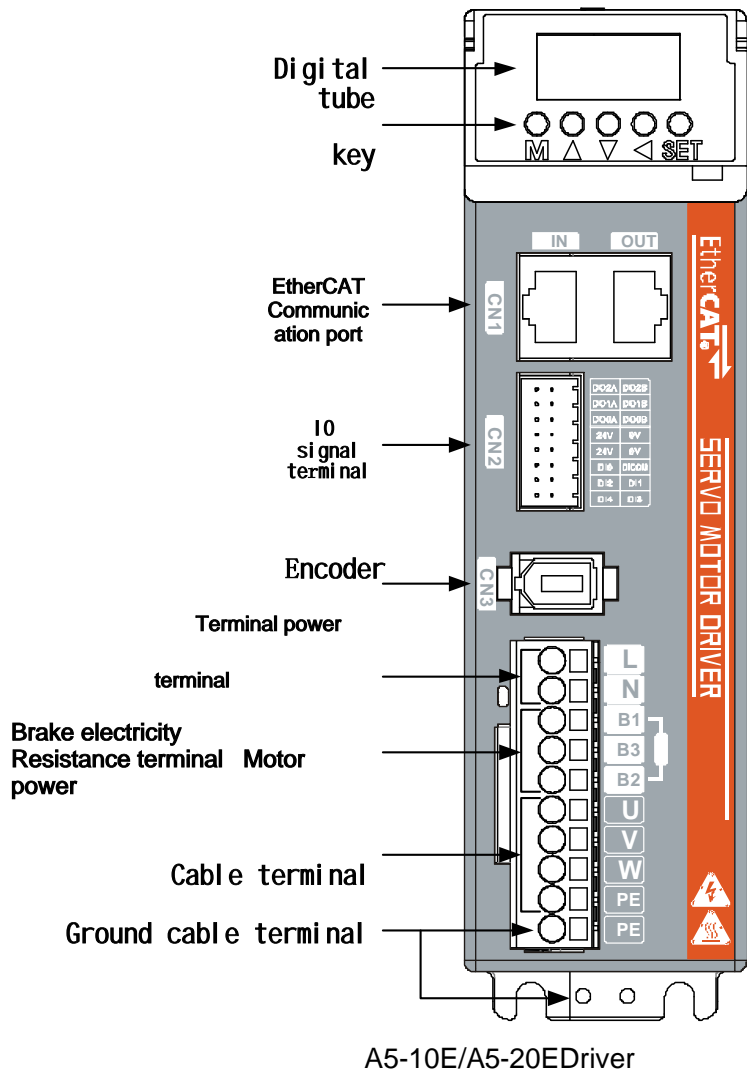

4.2 Main circuit wiring

4.2.1 Definition of Main Circuit Terminals

◆ A5-10E/A5-20E driver input power terminal

Serial Number	signal definition	Function
1	L	Power terminal, capable of connecting AC single-phase 220V
2	N	

◆ Brake resistor terminal

Pin	signal definition	Function	Instruction
1	B1	DC bus positive terminal output DC	The positive terminal of the built-in resistor is connected to B1. When using the built-in resistor, please short circuit B2 and B3. When using an external resistor, please connect the resistor between B1 and B2 (B2 and B3 must be disconnected).
2	B3	Built in brake resistor negative terminal output.	
3	B2	Brake transistor collector output	

◆ Motor terminals

Socket number	signal definition	Function
1	U	Connected to motor U-phase
2	V	Connected to motor V phase
3	W	Connected to motor W-phase
4	PE	Connected to motor housing

4.2.2 Main circuit power terminal (spring type) usage method

1. Peel off the outer skin of the wire to expose 8-9mm bare copper wire.

2. The pressing method is as follows:

- Pry open the slot using the control lever matched with the servo drive (as shown in Figure A);
- Insert a "straight" screwdriver into the terminal opening (end width 3.0-3.5mm), then firmly press to open the slot (as shown in Figure B).

3. The pressing method is as follows:



图 A



图 B

4.2.3 Driver wiring diagram

➤ A5-10E/A5-20E Driver Wiring Diagram

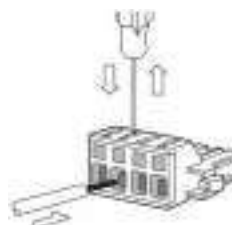
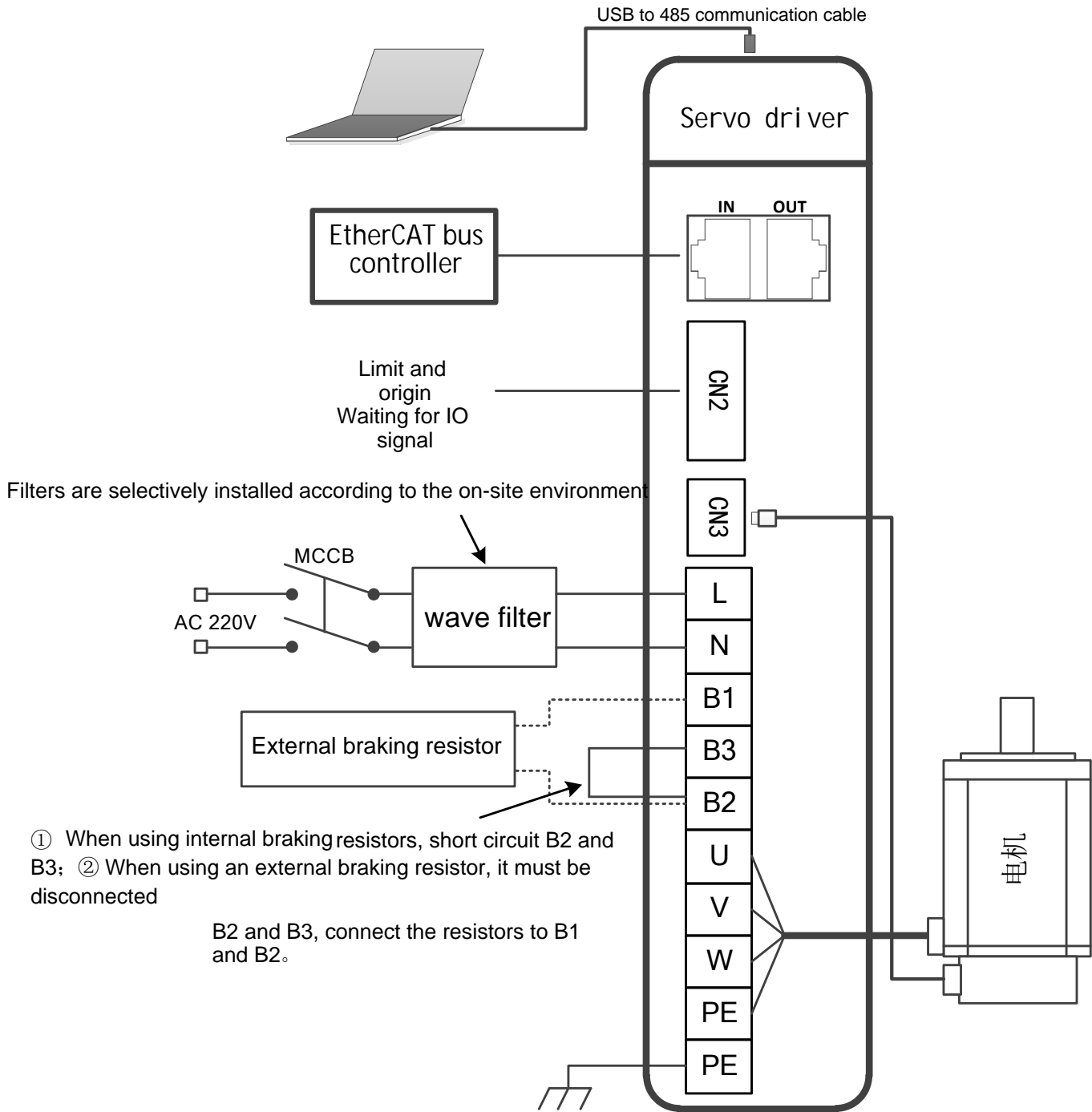

Note: When using internal braking resistors, short circuit B2 and B3 (already connected at the factory). When using external braking resistors, disconnect B2 and B3,

Connect the external braking resistor between B1 and B2.

4.3 Definition of wiring terminals

4.3.1 EtherCAT communication port definition (CN1)

Pin	signal definition	Signal instruction
1	TX+	EtherCATData sending positive end
2	TX-	EtherCAT data transmission negative end
3	RX+	EtherCAT data receiving positive end
4	/	/
5	/	/
6	RX-	EtherCAT data receiving negative terminal
7	/	/
8	/	/

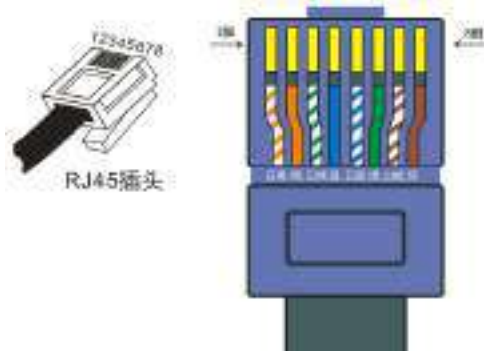

Crystal head pin sequence

4.3.2 Definition of Control Terminals (CN2)

Pin	Signal name	Function name	Notes or supplementary explanations	Terminal Definition Diagram
11	D00A	Digital output 0A terminal	Detailed description of parameter configuration, as described in Chapter 4.5.2. Attention: The maximum allowable current for the output port is 200mA, and it cannot directly drive high current loads such as motor brake. An external relay needs to be added.	
12	D00B	Digital output 0B end		
13	D01A	Digital output 1 A terminal		
14	D01B	Digital output 1B terminal		
15	D02A	Digital output 2A terminal	The maximum current output of 24V is 100mA, which can only be used as a DI port and pulse signal power supply. It is prohibited to use it to drive external loads.	
16	D02B	Digital output 2 B terminal		
7	24V	24V power output positive terminal		
9	24V			
8	0V	24V power output negative terminal	DICOM can be connected to +24V or 0V	
10	0V			
6	DICOM	DI port common terminal	Detailed description of parameter configuration, as described in Chapter 4.5.1.	
5	DI0	Digital input 0		
4	DI1	Digital input 1		
3	DI2	Digital input 2		
2	DI3	Digital input 3		
1	DI4	Digital input 4		

4.3.3 Encoder Terminal Definition (CN3)

◆ Driver encoder terminal schematic diagram

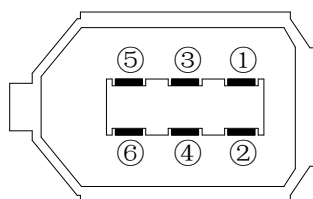

Encoder terminal pin diagram

◆ Driver encoder pin definition

Servo side		Name	Cable color
1	VCC	Encoder power supply+5V	Red
2	GND	Encoder power supply ground	Yellow
3	/	/	/
4	/	/	/
5	SD+	Encoder signal+	Blue
6	SD-	Encoder Signal-	Black

◆ Motor terminal diagram

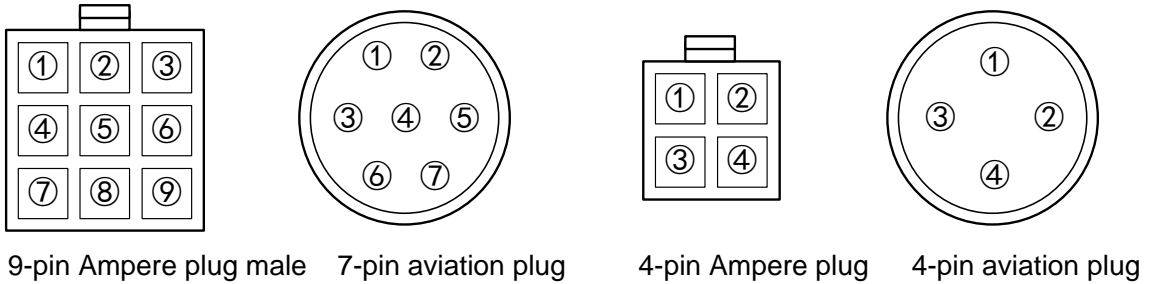

◆ Definition of motor encoder terminal pins (the definition of Amp head is the same as that of aviation head)

Motor side	Name	Cable color	
1	PE	Shielding wire	
2	E-	Battery powered negative pole	white
3	E+	Battery powered positive pole	Green
4	SD-	Encoder signal-	Black
5	GND	Encoder power supply ground	Yellow
6	SD+	Encoder signal+	Blue
7	VCC	Encoder power supply+5V	Red

◆ Definition of motor power line pins

Motor side (Amp plug)	Name	Line color	
1	U	Motor U-phase	Brown
2	V	Motor V-phase	Blue
3	W	Motor W-phase	Yellow
4	PE	motor housing	Green

4.3.4 Definition of Communication Terminals (CN4/CN5)

Pin	Cable color	Signal definition
1	White orange	GND
2	Orange	/
3	White green	/
4	Blue	485+
5	White blue	485-
6	Green	/
7	White brown	/
8	Brown	/

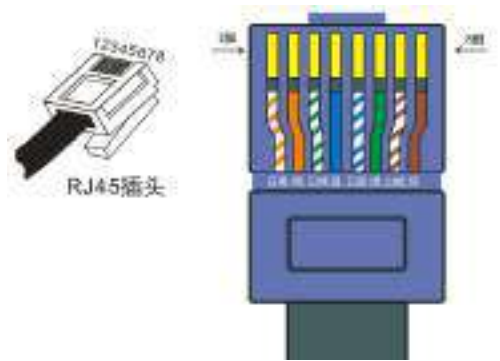

Crystal head pin sequence

4. 4 Control signal terminal wiring

4.4.1 DI input circuit

◆ NPNType input wire

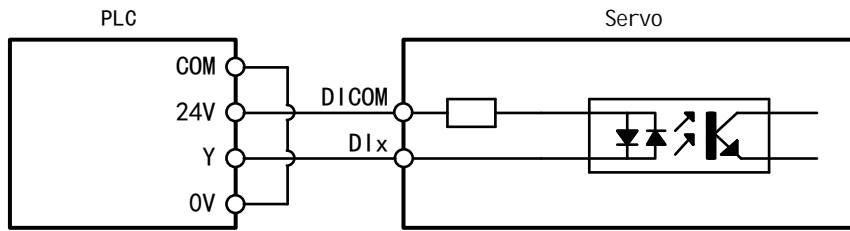

◆ PNPType input wire

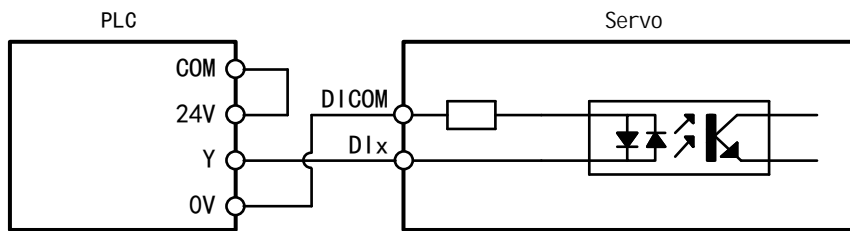

◆ Switch input wiring

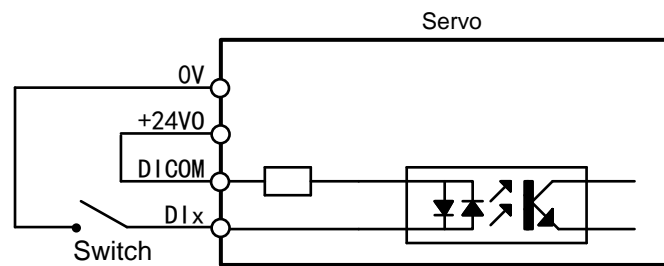

4.4.2DO output circuit

◆ DO output wiring (connecting optocoupler

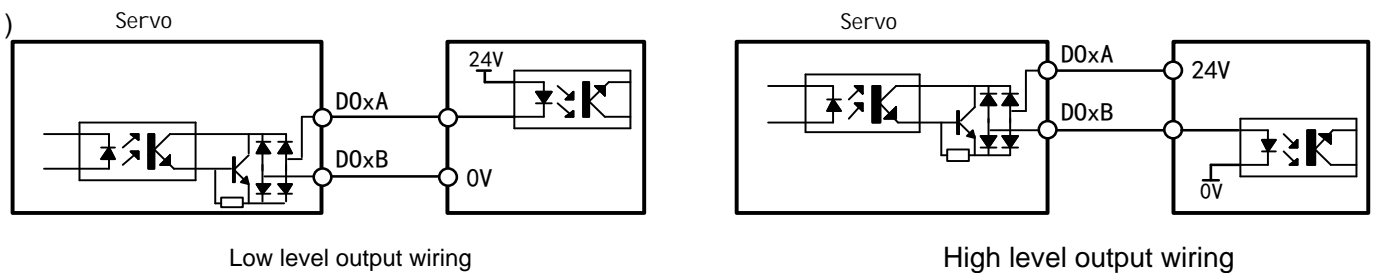

◆ DO output wiring (connecting relay)

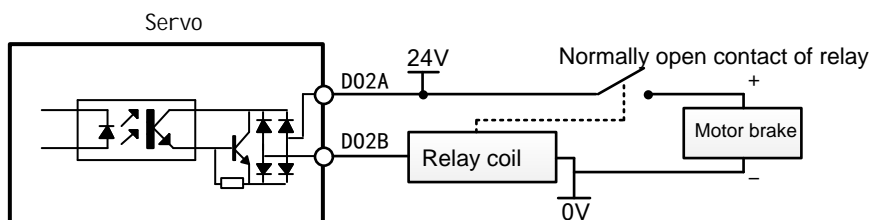

The output signal of the brake is controlled by a relay to control the motor to hold the brake

4.5 Detailed Description of DI/DO Port Function

Configuration 4.5.1 DI Function Description

1. DI port configuration parameters:

DI Port	Function selection			Logic level	
	parameter number	Initial value	Function Description	parameter number	Initial value
DI0	P03.02	14	Forward overtravel switch	P03.03	0
DI1	P03.04	15	Reverse overtravel switch	P03.05	0
DI2	P03.06	31	origin switch	P03.07	0
DI3	P03.08	0	–	P03.09	0
DI4	P03.10	0	–	P03.11	0

2. DI Port Function Command Table

Code	Name	Function name	Description	Remark
FunIN.14	P-OT	Forward overtravel switch	Effective - prohibit forward drive; Invalid - allows forward drive.	When the mechanical movement exceeds the movable range, enter the overtravel prevention function. The logical selection of the corresponding terminal is recommended to be set to: effective level.
FunIN.15	N-OT	Reverse overtravel switch	Effective - prohibit reverse drive; Invalid - reverse drive allowed.	
FunIN.31	HomeSwitch	origin switch	Invalid - not triggered; Effective - triggered.	The logical selection of the corresponding terminal must be set to: effective level. If set to 2 (effective rising edge), the internal drive will be forcibly changed to 1 (effective high level); If set to 3 (effective falling edge), the internal drive will be forcibly changed to 0 (effective low-level); If set to 4 (both rising and falling edges are effective), the driver will be forced to change to 0 internally (low level is effective)
FunIN.34	EmergencyStop	EMERGENCY STOP	Effective - position lock after zero speed shutdown; Invalid - has no impact on the current running state.	The logical selection of the corresponding terminal is recommended to be set to: effective level.
FunIN.38	TouchProbe1	Probe 1	Invalid - probe not triggered; Effective - Probe can trigger	The probe logic is only related to the probe function (60 B8h) and is not related to the terminal logic selection.
FunIN.39	TouchProbe2	Probe 2	Invalid - probe not triggered; Effective - the probe can be triggered.	The probe logic is only related to the probe function (60 B8h) and is not related to the terminal logic selection.

4.5.2 DO Function Description

1. DO port configuration parameters:

DI Port	Function selection			Logic level	
	parameter number	Initial value	Function Description	parameter number	Initial value
D00	P04.00	1	Servo ready	P04-01	0
D01	P04.02	5	Positioning Complete	P04-03	0
D02	P04.04	3	zero-speed	P04-05	0

2. DO Port Function Command Table

Code	Name	Function name	Description
FunOUT.1	S-RDY	Servo ready	The servo status is ready and can receive S-ON valid signals: valid - the servo is ready; Invalid - servo not ready.
FunOUT.2	TGON	Motor rotation output	When the speed is higher than 2006-11h: valid - the motor rotation signal is valid; Invalid - Motor rotation signal invalid.
FunOUT.5	COIN	Positioning Complete	When controlling the position, the position deviation pulse reaches the positioning completion threshold of 6067 hours, and the time reaches 6068 hours, which is effective.
FunOUT.7	C-LT	Torque limitation	Confirmation signal for torque limitation: effective - motor torque limitation; Invalid - motor torque is not limited.
FunOUT.8	V-LT	Speed limit	Confirmation signal for speed limitation during torque control: effective - motor speed limitation; Invalid - motor speed not limited.
FunOUT.9	BK	Band brake output	Holding brake signal output: effective - closed, releasing the holding brake; Invalid - activate the brake.
FunOUT.10	WARN	Warning output	The warning output signal is valid. (Conduction)

FunOUT. 11	ALM	fault output	The status is valid when a fault is detected.
FunOUT. 12	ALM01	Output a 3-digit alarm code	Output a 3-digit alarm code.
FunOUT. 13	ALM02	Output a 3-digit alarm code	Output a 3-digit alarm code.
FunOUT. 14	ALM03	Output a 3-digit alarm code	Output a 3-digit alarm code.
FunOUT. 18	ToqReach	Torque reaches output	Effective - the absolute torque value reaches the set value; Invalid - The absolute torque value is less than the set value reached.
FunOUT. 19	V-Arr	Speed output reached	Effective - Speed feedback reaches the set value; Invalid - Speed feedback did not reach the set value.

Chapter 5 Panel Display and Operation

5. 1 Panel Introduction and

Explanation

5.1.1 Panel Button Description

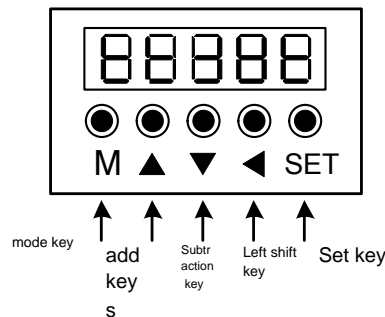

Name	General functions
M	Switch between modes to return to the previous menu level
▲	Increase the flicker bit value of LED digital tubes
▼	Reduce the flicker bit value of LED digital tubes
◀	Change the flashing position of the LED digital tube and view the high bit values of data with a length greater than 5 bits
SET	Enter the next level menu and execute commands such as storing parameter settings

5.1.2 Panel button operation method

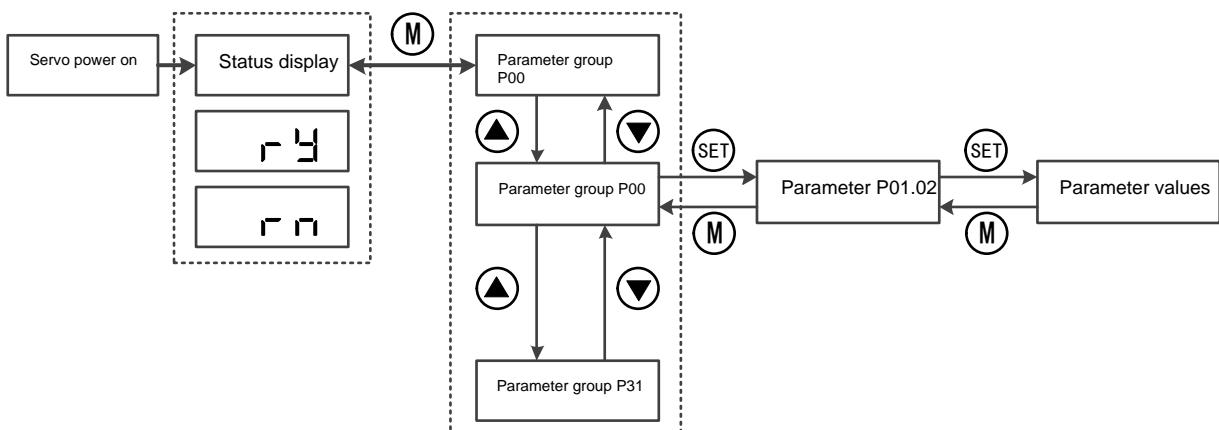

5.1.3 Parameter number display

The servo parameter number of this series consists of two parts: parameter group and internal parameter group number, as shown in the following figure:

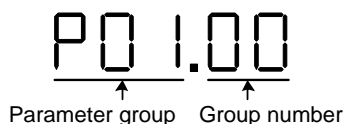

Object dictionary index=0x2000+parameter group number;
 Object dictionary sub-index = hexadecimal number of the parameter group +1;
 For example:

The object dictionary index of P02.03 is 2002-03h, and the object dictionary index of P0B.17 is 200b-12h.

5.1.4 Status Display

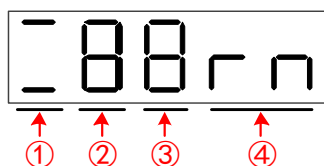

Display part	Display	Name	Display occasion	Meaning
①		Port 1 connection indication	The drive is ready and the servo enable signal is valid.	Long dark: No communication connection detected by the physical layer
		Port 0 connection indication		Steady on: A communication connection has been established at the physical layer
②		communication status	The drive is ready and the servo enable signal is valid.	The ETHERCAT state machine status of the slave. 1: Initialization state 2: Pre-running state 4: Safe operating status 8: Running status
③		control mode	The drive is ready and the servo enable signal is valid.	The current operating mode of the servo, does not flash. 0: No mode 1: Contour position control 3: Contour speed mode 4: Contour torque mode 6: Return to zero mode 8: Periodic synchronization position mode 9: Periodic synchronization speed mode A: Periodic synchronous torque mode
④		Nr Servo not ready	Servo initialization is complete, but the drive is not ready.	Because the main circuit is not powered on, the servo is in a non-operational state.
		Ry Servo is ready	The drive is ready	The servo drive is in an operational state and is waiting for the servo enable signal from the host computer.
		Rn Servo is running	The servo enable signal is valid	The servo drive is running.

5.1.5 Parameter Value Display

- Signed number of 4 digits and below or unsigned number of 5 digits and below

It adopts single page (5-digit digital tube) display. For signed numbers, the highest bit of data "-" represents a negative sign. Example: -9999 is displayed as follows:



Example: 65535 is displayed as follows:

65536

● **Signed number with more than 4 digits or unsigned number with more than 5 digits**

The display is divided into pages from low to high digits, and every 5 digits are one page.

The display method is: current page + current page value, as shown in the figure below, by long pressing "◀" key for more than 2 seconds to switch the current page. Example: -268435456 is displayed as follows:

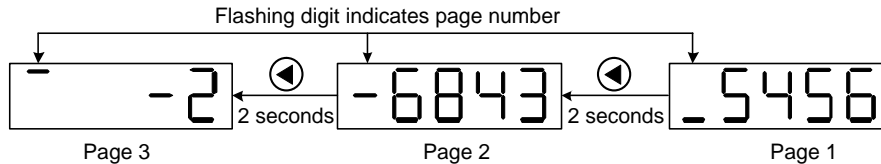

● **Modify the number of pulses per revolution in P05-02 and set the default value to 10000 to 1000 (the modification of other numerical parameters with more than 4 digits is the same as this step)**

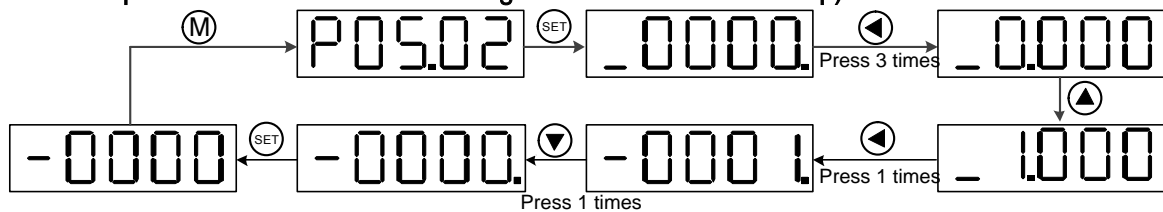

5.1.6 Monitoring Parameter Display (P0B group parameters)

function code	index	sub	name	Setting range	Unit	attribute	type
P0B.00	200B	01	Actual motor speed	The actual operating speed of the servo motor, accurate to 1rpm	rpm	R0	Int16
P0B.01	200B	02	speed command	Drive current speed command	rpm	R0	Int16
P0B.02	200B	03	Internal torque command (relative to rated torque)	Servo motor actual output torque as a percentage of motor rated torque	%	R0	Int16
P0B.03	200B	04	Input signal monitoring (DI signal)	The corresponding level status of the 5 DI terminals: the upper half of the digital tube lights up as high level; the lower half lights up as low level	-	R0	Int16
P0B.05	200B	06	Output signal monitoring (DO signal)	The corresponding level status of the 3 DO terminals: the upper half of the digital tube lights up to indicate high level, and the lower half of the digital tube lights up to indicate low level.	-	R0	Int16
P0B.07	200B	08	absolute position counter (32-digit decimal display)	Motor current absolute position (command unit)	command unit	R0	Int32
P0B.13	200B	0E	Input command pulse counter(32-digit decimal display)	Display the number of input position instructions	command unit	R0	Int32
P0B.15	200B	10	Encoder position deviation counter (32-digit decimal display)	Encoder position deviation = total number of input position instructions - total number of encoder feedback pulses	Encoder unit	R0	Int32
P0B.17	200B	12	Feedback pulse counter (32-digit decimal display)	Count and display the number of pulses fed back by the servo motor encoder	Encoder unit	R0	Int32
P0B.19	200B	14	Total power-on time (32-digit decimal display)	-	s	R0	Int32
P0B.24	200B	19	Phase current effective value	Servo motor phase current effective value	A	R0	Uint16
P0B.26	200B	1B	Bus voltage value	Main circuit DC bus voltage value	V	R0	Uint16
P0B.27	200B	1C	Module temperature value	-	°C	R0	Uint16
P0B.33	200B	22	Fault record	0. Current fault 1. Last failure ... 9. Last 9 failures	-	R0	Uint16
P0B.34	200B	23	Selected times fault code	P0B.33 Selected fault code When no fault occurs, the value displayed in P0B.34 is "Er.000"	-	R0	Uint16
P0B.35	200B	24	Selected failure timestamp	P0B.34 displays the total servo running time when the fault occurs. When no fault occurs, the value displayed in P0B.35 is "0"	s	R0	Int32
P0B.37	200B	26	Motor speed at selected fault	When the fault displayed by P0B.34 occurs, the servo motor speed	rpm	R0	Int16

				When no fault occurs, the value displayed in P0B.37 is "0"			
P0B. 38	200B	27	Motor U-phase current at selected fault	When the fault displayed by P0B.34 occurs, the effective value of the U-phase winding current of the servo motor does not occur. When the fault occurs, the value displayed by P0B.38 is "0".	A	RO	Int16
P0B. 39	200B	28	Motor U-phase current at selected fault	When the fault displayed by P0B.34 occurs, the effective value of the V-phase winding current of the servo motor does not occur. When the fault occurs, the value displayed by P0B.39 is "0".	A	RO	Int16
P0B. 40	200B	29	Bus voltage at selected fault	When the fault displayed by P0B.34 occurs, the DC bus voltage value of the main circuit has no value. When the fault occurs, the value displayed by P0B.40 is "0".	V	RO	UInt16
P0B. 41	200B	2A	Input terminal status at selected fault	When the fault displayed by P0B.34 occurs, the method of checking the high and low level status corresponding to the five DI terminals is the same as P0B.03; when no fault occurs, P0B.41 displays that all DI terminals are low level, and the corresponding decimal value is "0"	-	RO	UInt16
P0B. 42	200B	2B	Output terminal status at selected fault	When the fault displayed by P0B.34 occurs, the method of viewing the high and low level status corresponding to the three DO terminals is the same as P0B.05; when no fault occurs, P0B.42 displays that all DO terminals are low level, and the corresponding decimal value is "0"	-	RO	UInt16
P0B. 53	200B	36	Position deviation counter	Position deviation = total number of input position instructions (command unit) - total number of encoder feedback pulses (command unit)	command unit	RO	Int32
P0B. 55	200B	38	Actual motor speed	0.1rpm	rpm	RO	Int32
P0B. 57	200B	3A	Control electrical bus voltage	Control circuit DC bus voltage value	-	RO	UInt16
P0B. 58	200B	3B	Mechanical absolute position (lower 32 bits)	The lower 32-bit value of the mechanical corresponding position feedback	Encoder unit	RO	Int32
P0B. 60	200B	3D	Mechanical absolute position (high 32 bits)	Mechanical corresponding position feedback high 32-bit value	Encoder unit	RO	Int32
P0B. 64	200B	41	Real-time input position instruction counter	Displays the position command counter before electronic gear ratio multiplication.	command unit	RO	Int32
P0B. 70	200B	47	Absolute encoder revolutions	Displays the number of revolutions of the absolute encoder	r	RO	UInt16
P0B. 71	200B	48	Position within 1 revolution of absolute encoder	Display the single-turn position feedback value of the absolute encoder	Encoder unit	RO	Int32
P0B. 77	200B	4E	Absolute encoder absolute position (lower 32 bits)	Display the position feedback value of the absolute encoder, the lower 32-bit data	Encoder unit	RO	Int32
P0B. 79	200B	50	Absolute encoder absolute position (high 32 bits)	Display the position feedback value of the absolute encoder, the upper 32-bit data	Encoder unit	RO	Int32
P0B. 81	200B	52	Rotating load single-turn position (lower 32 bits)	Position feedback value of rotating load, lower 32-bit data	Encoder unit	RO	UInt32
P0B. 83	200B	54	Rotating load single-turn position (high 32 bits)	Position feedback value of rotating load, high 32-bit data	Encoder unit	RO	UInt32
P0B. 85	200B	56	Rotating load single turn position	Position feedback value of rotating load, high 32-bit data	command unit	RO	UInt32

5.2 Common operations



warn

- Before powering on, please check whether the driver wiring is correct.
- Make sure the motor is in an unloaded state to prevent collision or other dangerous situations.

5.2.1 Initialization parameters

Set P02-31 to 1 to initialize the drive parameters. After the settings are completed, the drive needs to be restarted.

5.2.2 Manual reset alarm

Set P0D.01 to 1 to clear the resettable alarm;

The multi-turn absolute encoder power-off alarm (Er.731) requires setting P0D.20 to 2 first, and then setting P0D.01 to 1 before the alarm can be cleared.

5.2.3 JOG mode operation

When using the jog operation function, you need to cancel the servo enable first, otherwise you cannot enter the JOG state!

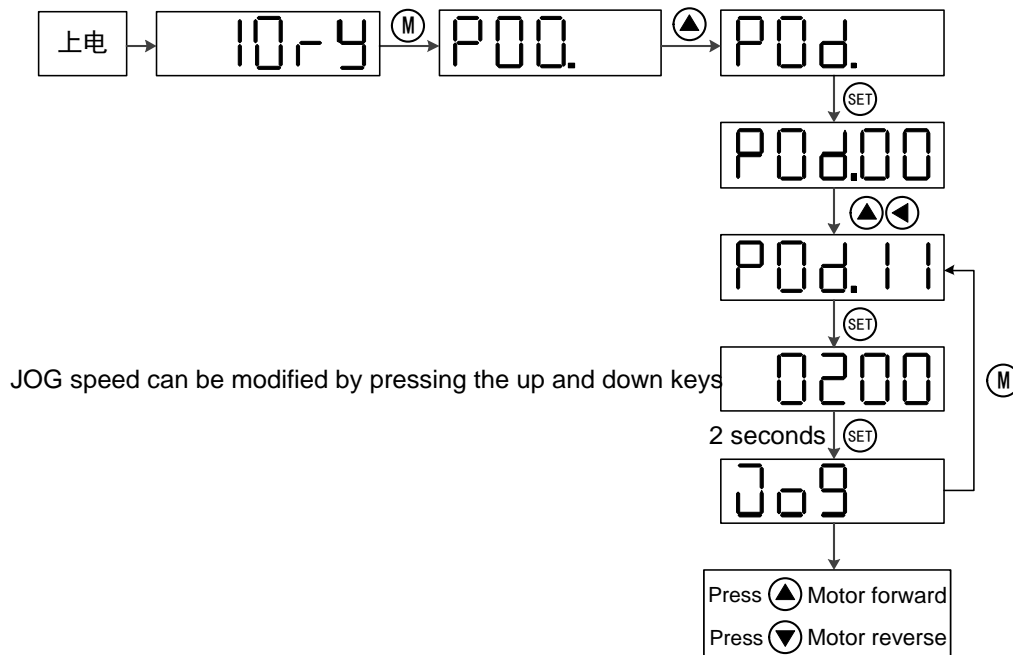

5.3 Gain parameter setting and description

Parameter number	Parameter name	Predetermined area	Function
P08.00	Speed loop gain	0.1~2000.0	This parameter determines the response of the speed loop. The larger the parameter is, the faster the speed loop will respond. However, setting it too high may cause vibration; In position mode, if you want to increase the position loop gain, you need to increase the speed loop gain at the same time.
P08.01	Speed loop integration time constant	0.15~512.00	The smaller the set value, the stronger the integral effect and the faster the response, which may cause jitter when using a large inertia load; the larger the setting value, the slower the response. When using a large inertia load, increase this parameter appropriately.
P08.02	Position loop gain	0.0~2000.0	This parameter determines the responsiveness of the position loop. Setting a larger position loop gain can shorten the positioning time. But setting it too high may cause vibration.
P08.15	Load inertia ratio	0.00~120.00	Sets the mechanical load inertia ratio relative to the motor's own moment of inertia. When the motor drives a belt/rack and pinion/swing arm and other large inertia loads, if there is back and forth shaking, this parameter can be increased.
P08.18	Speed feedforward filter time constant	0.00~64.00	Sets the filter time constant for velocity feedforward.
P08.19	Speed feed forward gain	0.0~100.0	Increasing this parameter can improve the position command response and reduce the position deviation at fixed speed. When adjusting, first set P08.18 to a fixed value; then gradually increase the setting value of P08.19 from 0 until the speed feedforward takes effect at a certain setting value.
P08.20	Torque feedforward filter time constant	0.00~64.00	Sets the filter time constant for torque feedforward.
P08.21	Torque feedforward gain	0.0~200.0	Increasing this parameter can improve the responsiveness to changing speed commands. Increasing this parameter can improve the position command response and reduce the position deviation at fixed speed.
P08.23	Speed feedback low-pass filter cutoff frequency	100~4000	The smaller the setting, the smaller the speed feedback fluctuation, but the greater the feedback delay.
P08.24	Pseudo-differential feedforward control coefficient	0.0~100.0	When this coefficient is set to 100.0, the speed loop adopts PI control (the default control method of the speed loop), and the dynamic response is fast; When set to 0.0, the speed loop integral effect is obvious and can filter out low-frequency interference, but the dynamic response is slow. By adjusting P08.24, the speed loop can be made to have faster responsiveness without increasing speed feedback overshoot, and it can also improve the anti-interference ability in the low frequency band.

Chapter 6 Communication Network Configuration

6.1 EtherCAT networking diagram

EtherCAT is an industrial Ethernet technology with high performance, low cost, easy application and flexible to pology. It can be used for industrial field-level ultra-high-speed I/O networks. It uses the standard Ethernet physical layer and the transmission media twisted pair or optical fiber (100Base-TX or 100Base-FX). The EtherCAT networking diagram is as follows:

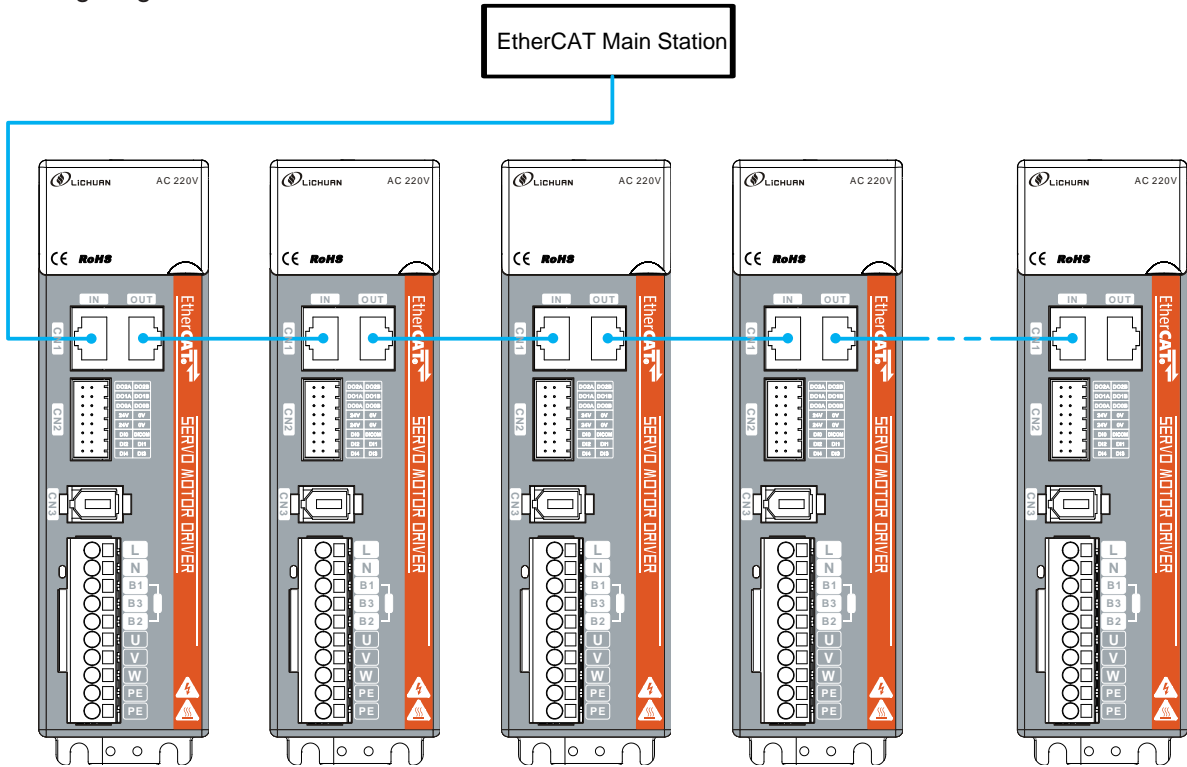

6.1.1 EtherCAT Communication technical specifications

Items		Speci fi cation
EtherCAT Basic performanc e of slave station	Protocol	EtherCAT Protocol
	Support servi ces	CoE (PDO、SDO)
	Synchronously	DC-Di stributed clock
	Physi cal layer	100BASE-TX
	Baud rate	100 Mbit/s (100Base-TX)
	Dupl ex mode	Ful l dupl ex
	Topol ogi cal structure	Li near
	Transmi ssi on medi um	Shielded Category 5e or Category 6 or above electrical performance specifications network cable
	Transmi ssi on di stance	Less than 100m between two nodes (good environment, good cables)
	Number of slaves	The protocol supports up to 65535, but the actual use does not exceed 100 units.
	EtherCAT Frame length	44 bytes to 1498 bytes
	Process data	Maximum size of a single Ethernet frame is 1486 bytes
	Synchronization jitter of two slaves	< 1us

6.2 Driver related parameter configuration

6.2.1 System parameter setting

In order to enable this series of servo drives to accurately connect to the EtherCAT fieldbus network, the relevant parameters of the servo drives need to be set. As shown in the following table:

Function code	Index	Sub Index	Name	Setting range	Unit	Factory settings	Effective method	Setting method	Related Patterns
P02.00	2002h	01	Control mode selection	9: EtherCAT Mode	-	9	Effective immediately	shutdown settings	-
P0C.13	200Ch	0E	Whether the communication write function code value is updated to EEPROM	0: Do not save 1: 2000h series object dictionary is written and stored in EEPROM after communication 2: 6000h series object dictionary is written and stored in EEPROM after communication 3: 2000h series and 6000h series object dictionary is written and stored in EEPROM after communication	-	3	Effective immediately	Run settings	PST

Note: The parameters that need to be saved in EEPROM must be set to the corresponding value in 200C-0Dh before setting. Otherwise, the parameters will return to their default values after powering on again.

6.2.2 Rotation direction selection

By setting "Rotation direction selection (2002-03h) or P02-02", the rotation direction of the motor can be changed without changing the input command polarity. The relevant parameters are as follows:

Function code	Index	Sub Index	Name	Setting range	Unit	Factory settings	Effective method	Setting method	Related Patterns
P02.02	2002h	03	Rotation direction selection	0: Take the CCW direction as the forward direction (A leads B) 1: Take the CW direction as the forward direction (A lags B)	-	0	Power on again	shutdown settings	PST

When the rotation direction selection (2002-03h) is changed, the shape of the servo drive output pulse and the positive and negative of the monitoring parameters will not change.

6.2.3 Brake settings

The holding brake is a mechanism that prevents the servo motor shaft from moving when the servo driver is in a non-running state and keeps the motor locked in position so that the moving parts of the machine will not move due to its own weight or external force. Under the relevant parameters:

Function code	Index	Sub Index	Name	Setting range	Unit	Factory settings	Effective method	Setting method	Related Patterns
P02.09	2002h	0A	Delay from brake output ON to command reception	0~500	ms	250	Effective immediately	Run settings	PS
P02.10	2002h	0B	In static state, delay from brake output OFF to motor de-energization	1~1000	ms	150	Effective immediately	Run settings	PS
P02.11	2002h	0C	Rotating state, speed threshold when brake output is OFF	0~3000	rpm	30	Effective immediately	Run settings	PS
P02.12	2002h	0D	Rotating state, delay from servo enable OFF to brake output OFF	1~1000	ms	500	Effective immediately	Run settings	PS

The brake output signal controls the motor brake wiring diagram through the relay, please refer to [Chapter 4.4.2](#).

6.3 Communication cycle of each mode

Period Time	Contour position mode (pp)	Return to zero mode (hm)	Periodic synchronized position mode(csp)	Cycle sync speed mode (csv)	Contour speed mode(pv)	Contour speed mode(pt)	Periodic synchronized torque mode(cst)
125us	×	×	×	×	×	√	√
250us	×	×	×	×	×	√	√
500us	×	×	×	√	√	√	√
1ms	√	√	√	√	√	√	√

The synchronization cycles supported by each mode of 1ms and below are as shown in the table above. Use outside the specifications may cause operation errors;

Above 1ms, the synchronization period whose value is an integral multiple of the position loop control period (the position loop control period is 250us) is also supported.

6.4 Process data PDO

6.4.1 Variable PDO mapping

This series of drives provides 1 variable RPDO and 1 variable TPDO for users to use. As shown in the following table:

Variable PDO	index	Maximum number of mappings	longest byte	Default mapping object
RPD01	1600h	10 个	40	6040h (control word) 607Ah (target location) 60B8h (probe function)
TPD01	1A00h	10 个	40	603Fh (error code) 6041h (status word) 6064h (position feedback) 60BCh (probe 2 rising edge position feedback) 60B9h (probe status) 60BAh (Probe 1 rising edge position feedback) 60FDh (DI status)

6.4.2 Fixed PDO mapping

This series of drives provides 5 fixed RPD0s and 4 fixed TPDOs for use. As shown in the following table:

PDO group	Supported servo modes	PP/CSP	PDO Group	Supported servo modes	PP/PV/PT/CSP/CSV/CST
Group 1	1701h (RPD0258)	Mapping object (3, 8 bytes)	Group 2	1702h (RPD0259)	Mapping objects (7, 19 bytes)
		6040h (control word) 607Ah (target location) 60B8h (probe function)			6040h (control word) 607Ah (target location) 60FFh (target speed) 6071h (target torque) 6060h (mode selection) 60B8h (probe function) 607Fh (maximum speed)
Group 1	1B01h (TPD0258)	Mapping object (8, 24 bytes)	Group 2	1B02h (TPD0259)	Mapping objects (9, 25 bytes)
		603Fh (error code) 6041h (status word) 6064h (position feedback) 6077h (torque feedback) 60F4 (position deviation) 60B9 (probe status) 60BA (Probe 1 rising edge position feedback) 60FD (DI status)			603Fh (error code) 6041h (status word) 6064h (position feedback) 6077h (torque feedback) 6061h (mode display) 60B9 (probe status) 60BA (Probe 1 rising edge position feedback) 60BC (Probe 2 rising edge position feedback) 60FD (DI status)

PDO group	Supported servo modes	PP/CSP	PDO Group	Supported servo modes	PP/PV/PT/CSP/CSV/CST
Group 1	1703h (RPD0260)	Mapping objects (7, 17 bytes)	Group 2	1704h (RPD0261)	Mapping objects (7, 17 bytes)
		6040h (control word) 607Ah (target location) 60FFh (target speed) 6060h (mode selection) 60B8h (probe function) 60E0h (forward torque limit) 60E1h (negative torque limit)			6040h (control word) 607Ah (target location) 60FFh (target speed) 6071h (target torque) 6060h (mode selection) 607Fh (maximum speed) 60B8h (probe function) 60E0h (forward torque limit) 60E1h (negative torque limit)
Group 1	1B03h (TPD0260)	Mapping object (10, 29 bytes)	Group 2	1B02h (TPD0259)	Mapping object (9, 25 bytes)
		603Fh (error code) 6041h (status word) 6064h (position feedback) 6077h (torque feedback) 60F4h (position deviation) 6061h (mode display) 60B9h (probe status) 60BAh (Probe 1 rising edge position feedback) 60BCh (Probe 2 rising edge position feedback) 60ED (DI status)			603Fh (error code) 6041h (status word) 6064h (position feedback) 6077h (torque feedback) 6061h (mode display) 60B9 (probe status) 60BA (Probe 1 rising edge position feedback) 60BC (Probe 2 rising edge position feedback) 60FD (DI status)

PDO group	Supported servo modes	PP/CSP	PDO Group	Supported servo modes
Group 5	1705h (RPD0262)	Mapping object (8, 19 bytes)	1B04h (TPD0261)	Mapping object (10, 29 bytes)
		6040h (control word) 607Ah (target location) 60FFh (target speed) 6060h (mode selection) 60B8h (probe function) 60E0h (forward torque limit) 60E1h (negative torque limit) 60B2h (torque bias)		603Fh (error code) 6041h (status word) 6064h (position feedback) 6077h (torque feedback) 6061h (mode display) 60F4h (position deviation) 60B9h (probe status) 60BAh (Probe 1 rising edge position feedback) 60BCh (Probe 2 rising edge position feedback) 606Ch (speed feedback)

Chapter 7 Control Mode Description

7.1 Control introduction

When using this series of drives, the servo drive must be guided according to the process specified in the standard 402 protocol, so that the servo drive can run in the specified state. Each status is described in the following table:

initialization	Drive initialization and internal self-test have been completed. The parameters of the drive cannot be set, and the drive function cannot be executed.
Servo has no fault	The servo drive has no fault or the error has been eliminated. Drive parameters can be set.
Servo ready	The servo drive is ready. Drive parameters can be set.
Waiting for servo enable to be turned on	The servo drive is waiting to turn on the servo enable. Drive parameters can be set.
Servo operation	The driver runs normally, a certain servo operation mode is enabled, the motor is powered on, and when the command is not 0, the motor rotates. The drive parameters whose attribute is "Run Change" can be set, but others cannot.
Quick shutdown	The quick stop function is activated and the drive is executing the quick stop function. The drive parameters whose attribute is "Run Change" can be set, but others cannot.
Fault shutdown	The drive has failed and is in the process of shutting down. The drive parameters whose attribute is "Run Change" can be set, but others cannot.
Fault	The fault shutdown is completed, all drive functions are disabled, and the drive parameters can be changed for troubleshooting.

The switching of control commands and status words is as follows:

CiA402 status switching		Corresponding value of control word 6040h	Bit0~bit9 of status word 6041h
0	Power on → initialize	Natural transition, no control instructions required	0x0000
1	Initialization → servo no fault	Natural transition, no control instructions required. If an error occurs during initialization, go directly to 13	0x0250
2	The servo is faultless → the servo is ready	6	0x0231
3	Servo is ready → waiting to turn on servo enable	7	0x0233
4	Waiting to turn on servo enable → servo running	F	0x0237
5	Servo running → waiting to turn on servo enable	7	0x0233
6	Waiting to turn on servo enable → Servo is ready	6	0x0231
7	Servo is ready → Servo is fault-free	0	0x0250
8	Servo running → Servo ready	6	0x0231
9	Servo is running → servo is fault-free	0	0x0250
10	Waiting to turn on the servo enable → the servo has no fault	0	0x0250
11	Servo operation → quick stop	2	0x0217
12	Quick stop → servo has no fault	Quick stop mode 605A is selected from 0 to 3. After the stop is completed, there will be a natural transition without control instructions.	0x0250
13	Fault shutdown	In any other state except "fault", once the servo drive fails, it will automatically switch to the fault shutdown state without control instructions.	0x021F
14	Fault shutdown → fault	After the fault shutdown is completed, there will be a natural transition without control instructions.	0x0218

15	Fault→Servo has no fault	0x80 Bit7 is valid on the rising edge; Bit7 remains 1, and other control instructions are invalid.	0x0250
16	Quick stop → servo operation	Quick stop mode 605A is selected from 5 to 7. After the stop is completed, 0x0F is sent.	0x0237

6.5.1 控制字 6040h

Bit 位	Name		Describe
0	Servo operation can be turned on	switch on	1: valid, 0: invalid
1	Turn on the main circuit power	enable voltage	1: valid, 0: invalid
2	Quick shutdown	quick stop	1: valid, 0: invalid
3	Servo operation	enable operation	1: valid, 0: invalid
4~6	Operating mode related	operation mode specific	Relevant to each servo operation mode
7	Fault reset	fault reset	For resettable faults and warnings, the fault reset function is executed; the rising edge of bit7 is valid; Bit7 remains 1, and other control instructions are invalid.
8	pause	halt	Please check the object dictionary 605Dh for the pause methods in each mode.
9	Operating mode related	operation mode specific	Relevant to each servo operation mode
10	N/A	N/A	N/A
11~15	N/A	N/A	N/A

6.5.2 Status word 6041h

Bit	Name		Describe
0	Servo ready	ready to switch on	1: valid, 0: invalid
1	Servo operation can be turned on	switch on	1: valid, 0: invalid
2	Servo operation	operation enabled	1: valid, 0: invalid
3	Fault	fault	1: valid, 0: invalid
4	The main circuit is electrically connected	voltage enabled	1: valid, 0: invalid
5	Quick shutdown	quick stop	1: valid, 0: invalid
6	Servo is not operational	switch on disabled	1: valid, 0: invalid
7	warn	warning	1: valid, 0: invalid
8	N/A	N/A	N/A
9	remote control	remote	1: valid, 0: invalid
10	target reached	target reach	1: valid, 0: invalid
11	Internal restrictions are in effect	internal limit active	1: valid, 0: invalid
12~13	Operating mode related	operation mode specific	Relevant to each servo operation mode
14	N/A	N/A	N/A
15	Origin found	Home Find	1: valid, 0: invalid

7.2 Working mode

7.2.1 Introduction to servo mode

The control modes supported by this series of servo drives are:

index	subindex	Name	set value	explanation
6060h	00	Operating mode	1	Contour position mode (pp)
			3	Profile velocity mode (pv)
			4	Profile torque mode (pt)
			6	Return to zero mode (hm)
			8	Cyclic synchronized position mode (csp)
			9	Cycle synchronized velocity pattern (csv)
			10	Periodic synchronized torque mode (cst)

7.2.2 Servo mode switching

1. When the servo drive is in any state, after switching from the contour position mode or the periodic synchronous position mode to other modes, the unexecuted position instructions will be discarded.
2. When the servo drive is in any state, after switching from contour speed mode, contour torque mode, period synchronous speed mode, period synchronous torque mode to other modes, it will first perform a ramp stop. After the shutdown is completed, it can switch to other modes.
3. When the servo is in the zero return mode and is running, it cannot switch to other modes; when the zero return is completed or interrupted (fault or enable invalid), it can switch to other modes.
4. In the servo running state, when switching from other modes to running in periodic synchronization mode, please wait at least 1ms before sending instructions, otherwise instruction loss or errors will occur.

7.3 Periodic synchronized position mode (CSP mode)

Set the 6060h to 8 and the drive is in CSP mode. In the periodic synchronization position mode, the upper controller completes the position command planning, and then sends the planned target position 607Ah to the servo driver in a periodic synchronization manner. The position, speed, and torque control are completed internally by the servo driver. This mode is suitable for multi-axis synchronous position control. The commonly used object dictionary using CSP mode is as follows:

Index	Subindex	Name	Access Type	Type of Data	Unit	Configuration recommendations
603Fh	00	Error code	RO	UINT16	-	Recommended configuration
6041h	00	Status word	RO	UINT16	-	Must be configured
6061h	00	Mode display	RO	INT8	-	Configure when needed
6062h	00	Position command	RO	INT32	command unit	Configure when needed
6064h	00	Position feedback	RO	INT32	command unit	Configure when needed
606Ch	00	Actual speed	RO	INT32	command unit/S	Configure when needed
60F4h	00	Position deviation	RO	INT32	command unit	Configure when needed
60FCh	00	Position command	RO	INT32	encoder unit	Configure when needed
60FDh	00	Input I/O status	RO	UINT32	-	Configure when needed
6040h	00	Control word	RW	UINT16	-	Must be configured
6060h	00	Control mode	RW	INT8	-	Recommended configuration
607Ah	00	Target position	RW	INT32	command unit	Must be configured
607Fh	00	Maximum rotation speed	RW	UDINT	command unit	Configure when needed

6065h	00	Position deviation excessive threshold	RW	UINT32	command unit	Configure when needed
6067h	00	Position reaches threshold	RW	UINT32	encoder unit	Configure when needed
6068h	00	Location arrival window	RW	UINT16	ms	Configure when needed
6091h	01	Motor resolution	RW	UINT32	-	Configure when needed
	02	Axis resolution	RW	UINT32	-	Configure when needed
60B0h	00	Position offset	RW	INT32	command unit	Configure when needed
60B1h	00	Speed bias	RW	INT32	command unit/S	Configure when needed
60B2h	00	Torque bias	RW	INT32	0.1%	Configure when needed
6072h	00	Maximum torque	RW	UINT16	0.1%	Configure when needed
60E0h	00	Forward torque limit	RW	UINT16	0.1%	Configure when needed
60E1h	00	Forward torque limit	RW	UINT16	0.1%	Configure when needed

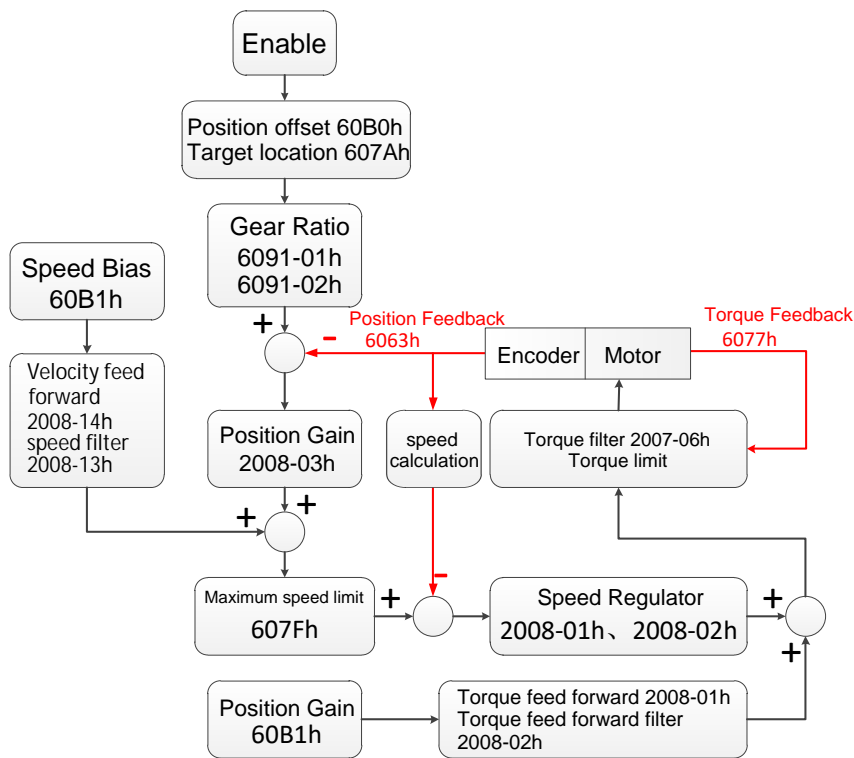

CSP mode control block diagram

7.4 Periodic synchronization speed mode (CSV mode)

Set 6060h to 9 and the drive is in CSV mode. In the periodic synchronous speed mode, the upper controller periodically and synchronously sends the calculated target speed 60FF to the servo driver, and the speed and torque adjustment are performed internally by the servo. This mode is suitable for multi-axis synchronous speed control. The commonly used object dictionary using CSV mode is as follows:

index	subindex	Name	access type	type of data	Unit	Configuration recommendations
603Fh	00	Error code	RO	UINT16	-	Rconfiguration
6041h	00	Status word	RO	UINT16	-	Must be configured
6061h	00	Mode display	RO	INT8	-	Configure when needed
6064h	00	Position feedback	RO	INT32	command unit	Configure when needed
606Ch	00	Actual speed	RO	INT32	command unit/S	Configure when needed
6077h	00	Actual torque	RO	INT16	0.1%	Configure when needed

6040h	00	control word	RW	UINT16	-	Must be configured
6060h	00	control mode	RW	INT8	-	Recommended configuration
60FFh	00	target speed	RW	INT32	command unit/s	Must be configured
607Fh	00	Maximum speed	RW	UDINT32	command unit/s	Configure when needed
60B1h	00	speed bias	RW	INT32	command unit/s	Configure when needed
60B2h	00	Torque bias	RW	INT32	0.1%	Configure when needed
6072h	00	Maximum torque	RW	UINT16	0.1%	Configure when needed
60E0h	00	Forward torque limit	RW	UINT16	0.1%	Configure when needed
60E1h	00	Reverse torque limit	RW	UINT16	0.1%	Configure when needed

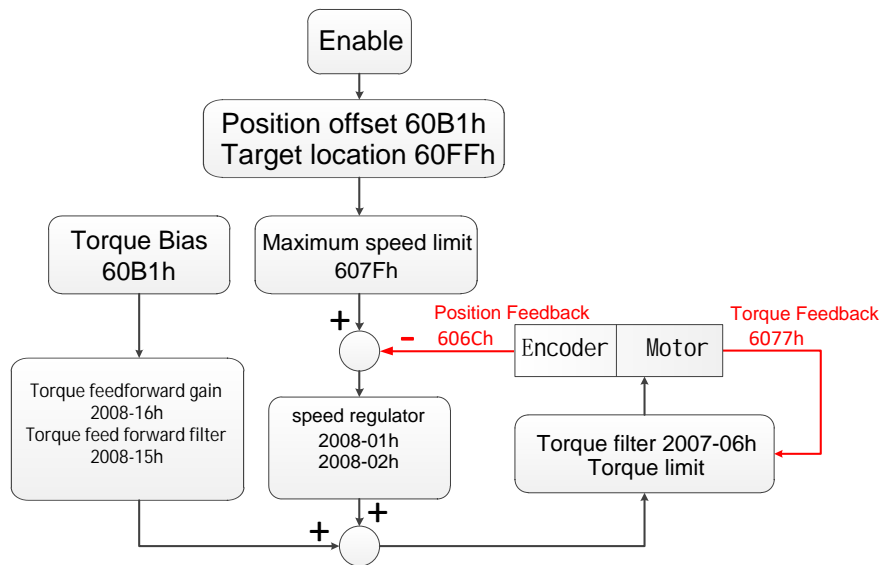

CSV mode control block diagram

7.5 Periodic synchronous torque mode (CST mode)

Set 6060h to 10, and the drive is in CST mode. In the periodic synchronous torque mode, the upper controller periodically and synchronously sends the calculated target torque 6071h to the servo drive, and the torque adjustment is performed internally by the servo. When the speed reaches the limit value, it will enter the speed adjustment stage. This mode is suitable for multi-axis synchronous torque control. The common object dictionary used in CST mode is as follows:

index	subindex	name	access type	type of data	Unit	Configuration recommendations
603Fh	00	error code	RO	UINT16	-	Suggested configuration
6041h	00	status word	RO	UINT16	-	Must be configured
6061h	00	Mode display	RO	INT8	-	Configure when needed
606Ch	00	actual speed	RO	INT32	command unit/s	Configure when needed
6074h	00	Torque command	RO	INT16	0.1%	Configure when needed
6077h	00	actual torque	RO	INT16	0.1%	Configure when needed
6040h	00	control word	RW	UINT16	-	Must be configured
6060h	00	control mode	RW	INT8	-	Configure when needed
6071h	00	target torque	RW	INT16	0.1%	Must be configured
607Fh	00	Maximum speed	RW	UDINT32	command unit/s	Suggested configuration
60B2h	00	Torque bias	RW	INT32	0.1%	Configure when needed
6072h	00	Maximum torque	RW	UINT16	0.1%	Configure when needed
60E0h	00	Forward torque limit	RW	UINT16	0.1%	Configure when needed
60E1h	00	Reverse torque limit	RW	UINT16	0.1%	Configure when needed

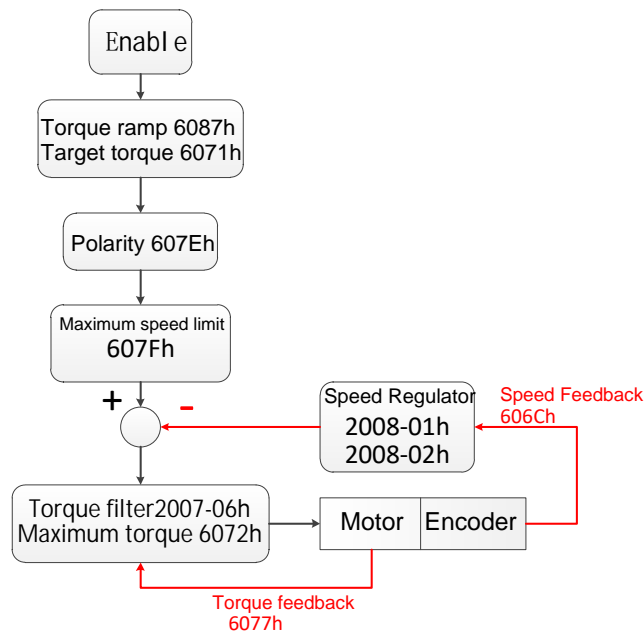

CSTMode control flow block diagram

7.6 Profile position mode (PP mode)

Set 6060h to 1 and the drive is in pp mode. This mode is mainly used for point-to-point positioning applications. In this mode, the host computer gives the target position (absolute or relative), the speed of the position curve, acceleration and deceleration, and deceleration. The trajectory generator inside the servo will generate the target position curve command according to the settings. The driver completes position control and speed control internally. Torque control. Commonly used object dictionaries using pp mode are as follows:

index	subindex	Name	access type	type of data	Unit	Configuration recommendations
603Fh	00	error code	RO	UINT16	-	Recommended configuration
6041h	00	status word	RO	UINT16	-	Must be configured
6061h	00	Mode display	RO	INT8	-	Configure when needed
6062h	00	position command	RO	INT32	command unit	Configure when needed
6063h	00	position feedback	RO	INT32	encoder unit	Configure when needed
6064h	00	position feedback	RO	INT32	command unit	Configure when needed
606Ch	00	actual speed	RO	INT32	command unit/S	Configure when needed
60F4h	00	position deviation	RO	INT32	command unit	Configure when needed
60FCh	00	position command	RO	INT32	encoder unit	Configure when needed
60FDh	00	Enter IO status	RO	UINT32	-	Configure when needed
6077h	00	actual torque	RO	INT16	0.1%	Configure when needed
6040h	00	control word	RW	UINT16	-	Must be configured
6060h	00	control mode	RW	INT8	-	Configure when needed
607Ah	00	target location	RW	INT32	command unit	Must be configured
6081h	00	Profile speed	RW	UDINT32	Command unit/S	Must be configured
6083h	00	acceleration	RW	UDINT32	Command unit/S ²	Recommended configuration
6084h	00	deceleration	RW	UDINT32	Command unit/S ²	Recommended configuration
6065h	00	Position deviation excessive threshold	RW	UINT32	command unit	Configure when needed
6067h	00	Position reaches threshold	RW	UINT32	encoder unit	Configure when needed
6068h	00	location arrival window	RW	UINT16	ms	Configure when needed
6072h	00	Maximum torque	RW	UINT16	0.1%	Configure when needed
6091h	01	Motor resolution	RW	UINT32	-	Configure when needed

	02	Axis resolution	RW	UINT32	-	Configure when needed
60E0h	00	Forward torque limit	RW	UINT16	0.1%	Configure when needed
60E1h	00	Reverse torque limit	RW	UINT16	0.1%	Configure when needed

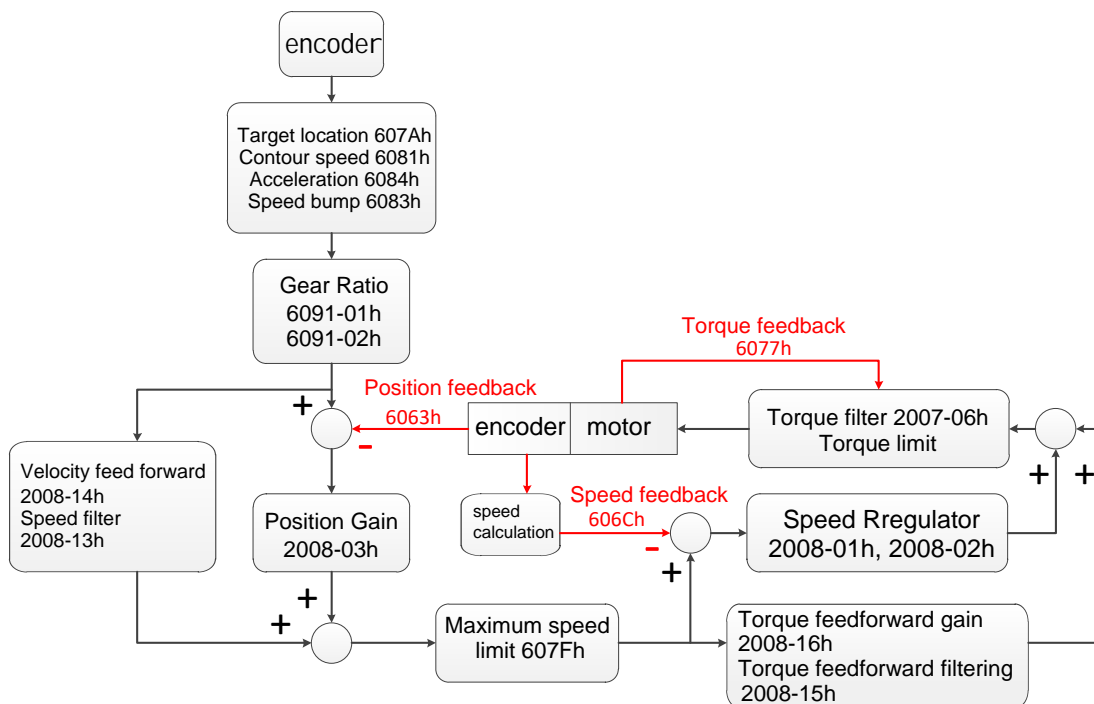

PP mode control flow block diagram

7.7 Profile speed mode (PV mode)

Set 6060h to 3 and the drive is in pv mode. In this mode, the upper controller sends the target speed, acceleration, and deceleration to the servo driver, and the speed and torque adjustment are performed internally by the servo. Commonly used object dictionaries using pv mode are as follows:

index	subindex	Name	Access type	type of data	Unit	Configuration recommendations
603Fh	00	error code	RO	UINT16	-	Recommended configuration
6041h	00	status word	RO	UINT16	-	Must be configured
6061h	00	Mode display	RO	INT8	-	Configure when needed
6063h	00	position feedback	RO	INT32	Encoder unit	Configure when needed
6064h	00	position feedback	RO	INT32	command unit	Configure when needed
606Ch	00	actual speed	RO	INT32	command unit/S	Configure when needed
6077h	00	actual torque	RO	INT16	0.1%	Configure when needed
6040h	00	control word	RW	UINT16	-	Must be configured
6060h	00	control mode	RW	INT8	-	Configure when needed
60FFh	00	target speed	RW	INT32	command unit/S	Must be configured
6083h	00	acceleration	RW	UDINT32	command unit/S	Recommended configuration
6084h	00	deceleration	RW	UDINT32	command unit/S	Recommended configuration
607Fh	00	Maximum speed	RW	UDINT32	command unit/S	Recommended configuration
606Dh	00	speed reaches threshold	RW	INT32	command unit/S	Configure when needed
606Eh	00	speed arrival window	RW	INT32	ms	Configure when needed
60B1h	00	speed bias	RW	INT32	command unit/S	Configure when needed
60B2h	00	Torque bias	RW	INT32	0.1%	Configure when needed
60E0h	00	Forward torque limit	RW	UINT16	0.1%	Configure when needed
60E1h	00	Reverse torque limit	RW	UINT16	0.1%	Configure when needed

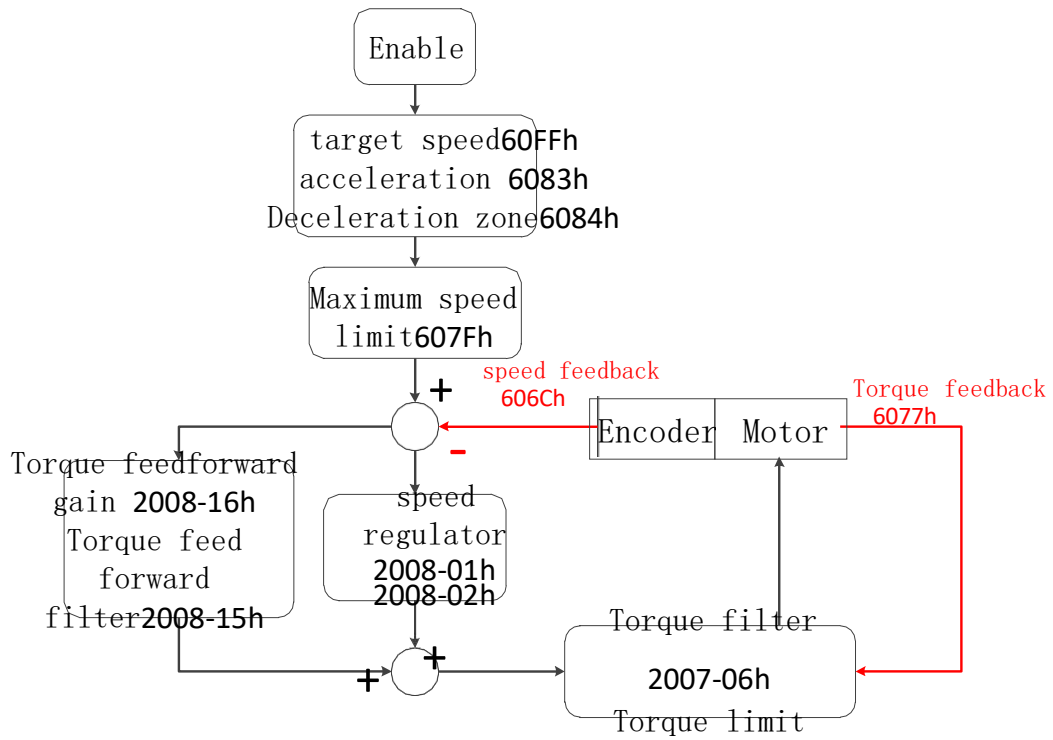

(PV mode control flow block diagram)

7.8 Profile torque mode (PT mode)

Set 6060h to 4 and the drive is in pt mode. In this mode, the upper controller sends the target torque 6071h and torque ramp constant :

index	subindex	Name	access type	type of data	Unit	Recommended configuration
603Fh	00	error code	RO	UINT16	-	Recommended configuration
6041h	00	status word	RO	UINT16	-	Must be configured
6061h	00	Mode display	RO	INT8	-	Configure when needed
606Ch	00	actual speed	RO	INT32	command unit/S	Configure when needed
6074h	00	Torque command	RO	INT16	0.1%	Configure when needed
6077h	00	actual torque	RO	INT16	0.1%	Configure when needed
6040h	00	control word	RW	UINT16	-	Must be configured
6060h	00	control mode	RW	INT8	-	Configure when needed
6071h	00	target torque	RW	INT16	0.1%	Must be configured
6087h	00	Torque ramp	RW	UDINT32	0.1%/S	Recommended configuration
607Fh	00	Maximum speed	RW	UDINT32	command unit/S	Recommended configuration
6072h	00	Maximum torque	RW	UINT16	0.1%	Recommended configuration
60B2h	00	Torque bias	RW	INT32	0.1%	Configure when needed
60E0h	00	Forward torque limit	RW	UINT16	0.1%	Configure when needed
60E1h	00	Reverse torque limit	RW	UINT16	0.1%	Configure when needed

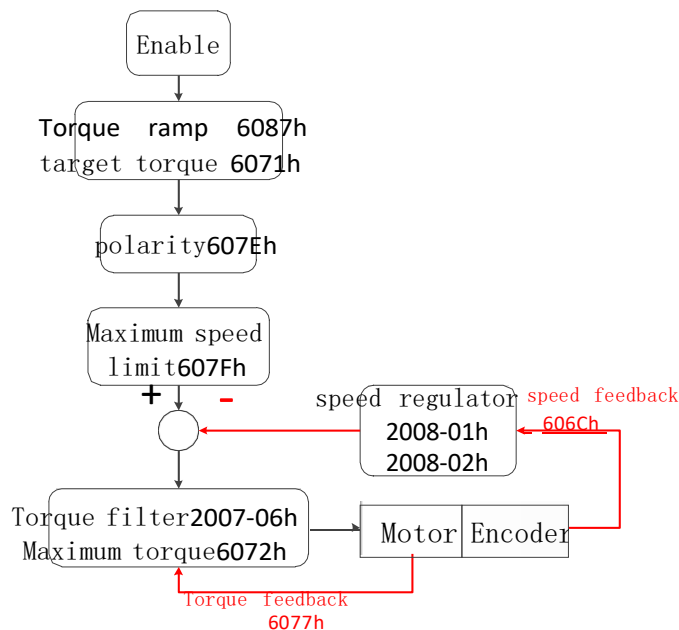

PT mode control block diagram

7.9 Return to zero mode (HOME mode)

Set 6060h to 6 and the drive is in HOME mode. The origin return mode is used to find the mechanical origin and locate the positional relationship between the mechanical origin and the mechanical zero point. Mechanical origin: a fixed position on the machine, which can correspond to a certain origin switch and the motor Z signal. Mechanical zero point: Mechanically the absolute 0 position. After the origin is returned to zero, the motor stop position is the mechanical origin. By setting 607Ch, the relationship between the mechanical origin and the mechanical zero can be set: mechanical origin = mechanical zero + 607Ch (origin offset). When 607Ch = 0, the mechanical origin and Mechanical zero point coincidence. Zero return mode 6098h Please refer to the appendix. The dictionary of commonly used objects using hm mode is as follows

:

index	subindex	Name	access type	type of data	Unit	Recommended configuration
603Fh	00	error code	R0	UINT16	-	Recommended configuration
6041h	00	status word	R0	UINT16	-	Must be configured
6061h	00	Mode display	R0	INT8	-	Configure when needed
6064h	00	position feedback	R0	INT32	command unit	Configure when needed
606Ch	00	actual speed	R0	INT32	command unit/S	Configure when needed
6077h	00	actual torque	R0	INT16	0.1%	Configure when needed
60FDh	00	Enter IO status	R0	UINT32	-	Configure

						when needed
60F4h	00	position deviation	RO	DINT32	command unit	Recommended configuration
6040h	00	control word	RW	UINT16	-	Must be configured
6060h	00	control mode	RW	INT8	-	Configure when needed
6098h	00	Zero return method	RW	INT8	-	Must be configured
6099h	01	Return to Zero Expressway	RW	UINT32	command unit/S	Must be configured
	02	Return to zero low speed	RW	UINT32	command unit/S	Must be configured
609Ah	00	acceleration	RW	UDINT32	command unit/S ²	Must be configured
2005h	24	Return to zero timeout	RW	UINT16	10ms	Recommended configuration
6065h	00	Position deviation excessive threshold	RW	UINT32	command unit	Configure when needed
6067h	00	Position reaches threshold	RW	UINT32	Encoder unit	Configure when needed
6068h	00	location arrival window	RW	UINT16	ms	Configure when needed

7.7.1 Functional description of 60B8h and 60B9h

index	subindex	Function Description	
60B8h	00h	Bit0	0: Probe 1 is disabled; 1: Probe 1 is enabled;
		Bit1	0: Probe 1 single mode; 1: Probe 1 continuous mode;
		Bit2	Probe 1 trigger signal selection: 0: DI3; 1: Z signal;
		Bit3	reserve
		Bit4	0: The rising edge of probe 1 is not enabled; 1: The rising edge of probe 1 is enabled;
		Bit5	0: The falling edge of probe 1 is not enabled; 1: The falling edge of probe 1 is enabled;
		Bit6~ Bit7	reserve;
		Bit8	0: Probe 2 is not enabled; 1: Probe 2 is enabled;
		Bit9	0: Probe 2 single mode; 1: Probe 2 continuous mode;
		Bit10	Probe 2 trigger signal selection: 0: DI4; 1: Z signal;
		Bit11	reserve;
		Bit12	0: The rising edge of probe 2 is not enabled; 1: The rising edge of probe 2 is enabled;
		Bit13	0: The falling edge of probe 2 is not enabled; 1: The falling edge of probe 2 is enabled;
		Bit14~ Bit15	reserve;

60B9h	00h	Bit0	0: Probe 1 is not in action; 1: Probe 1 is working;
		Bit1	0: The rising edge capture of probe 1 is not completed; 1: The rising edge capture of probe 1 is completed;
		Bit2	0: Probe 1 falling edge capture is not completed; 1: Probe 1 falling edge capture is completed;
		Bit3~Bit5	reserve;
		Bit6	Probe 1 trigger signal selection: 0: DI3; 1: Z signal;
		Bit7	Probe 1 trigger signal monitoring: 0: DI3 low level; 1: DI3 high level;
		Bit8	0: Probe 2 is not in action; 1: Probe 2 is working;
		Bit9	0: Probe 2 rising edge capture is not completed; 1: Probe 2 rising edge capture is completed;
		Bit10	0: Probe 2 falling edge capture is not completed; 1: Probe 2 falling edge capture is completed;
		Bit11~Bit13	reserve;
		Bit14	Probe 2 trigger signal selection: 0: DI4; 1: Z signal;
		Bit15	Probe 2 trigger signal monitoring: 0: DI4 low level; 1: DI4 high level;

7.8.2 Reading the probe latch position

The four position information of the probe are recorded in objects 0x60BA~0x60BD respectively. As shown in the figure below, the probe 1 rising edge position latch function has been executed. By reading 0x60BA (probe 1 rising edge position feedback latch value, command unit) Location information can be read. The single probe works as follows :

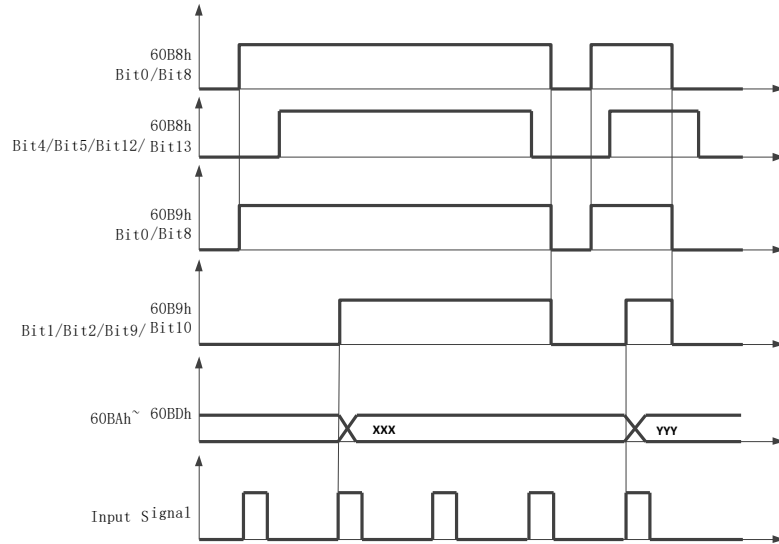

The continuous probe works as follows:

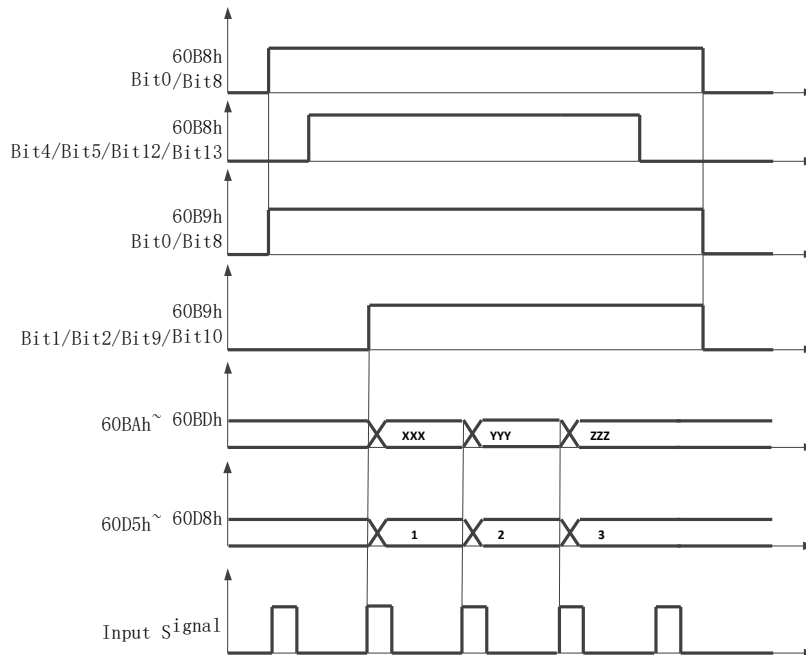

Chapter 8 Parameter Description

8.1 1000 Group of object dictionary parameters

index	subindex	Name	Unit	Change method	illustrate	Attributes
1000	00	Equipment type	-	cannot be changed	CIA standards	RO
1001	00	error register	-	cannot be changed	CIA designated error register	RO
1008	00	Manufacturer equipment name	-	cannot be changed		RO
1009	00	Manufacturer hardware version	-	cannot be changed		RO
100A	00	Manufacturer software version	-	cannot be changed		RO
1018	00	Number of sub-indexes	-	cannot be changed	NONE	RO
	01	Vendor ID	-	cannot be changed	NONE	RO
	02	Product Code	-	cannot be changed	NONE	RO
	03	Modify encoding	-	cannot be changed	NONE	RO
	04	serial number	-	cannot be changed	NONE	RO
1C00	00	Synchronization management communication type maximum sub-index number	-	cannot be changed	-	RO
	01	S0 communication type	-	cannot be changed	-	RO
	02	S1 communication type	-	cannot be changed	-	RO
	03	S2 communication type	-	cannot be changed	-	RO
	04	S3 communication type	-	cannot be changed	-	RO
1600	00	Number of mapping objects supported by RPD01	-	Live changes	NONE	RW
	01~0A	RxPDO mapping object group 1	-	Live changes	Default RxPDO mapping group 1	RW
1701	00	Number of mapping objects supported by RPD0258	-	cannot be changed	-	RO

	01~04	mapping object	-	cannot be changed	-	RO
1702	00	Number of mapping objects supported by RPD0259	-	cannot be changed	-	RO
	01~07	mapping object	-	cannot be changed	-	RO
1703	00	Number of mapping objects supported by RPD0260	-	cannot be changed	-	RO
	01~07	mapping object	-	cannot be changed	-	RO
1704	00	Number of mapping objects supported by RPD0261	-	cannot be changed	-	RO
	01~09	mapping object	-	cannot be changed	-	RO
1705	00	Number of mapping objects supported by RPD0262	-	cannot be changed	-	RO
	01~08	mapping object	-	cannot be changed	-	RO
1A00	00	Number of mapping objects supported by TPD01	-	Live changes	NONE	RW
	01~0A	TxPDO mapping object group 1	-	Live changes	Default TxPDO mapping group 1	RW
1B01	00	Number of mapping objects supported by TPD0258	-	cannot be changed	-	RO
	01~08	mapping object	-	cannot be changed	-	RO
1B02	00	Number of mapping objects supported by TPD0259	-	cannot be changed	-	RO
	01~09	mapping object	-	cannot be changed	-	RO
1B03	00	Number of mapping objects supported by TPD0260	-	cannot be changed	-	RO
	01~0A	mapping object	-	cannot be changed	-	RO
1B04	00	Number of mapping objects supported by TPD0261	-	cannot be changed	-	RO
	01~0A	mapping object	-	cannot be changed	-	RO
1C12	00~01	RxPDO allocation	-	Live changes	NONE	RW
1C13	00~01	TxPDO allocation	-	Live changes	NONE	RW
1C32	00~0A	RxPDO management parameters	-	Live changes	NONE	RO
1C33	00~0A	TxPDO management parameters	-	Live changes	NONE	RO

8.2 2000 Group Object Dictionary Parameters

8.2.1 2001 Group object dictionary (P01 group parameter)

function code	index	subindex	Name	Predetermined area	Unit	Factory set up	Setting takes effect	Attributes	Type
P01.02	2001	03	Servo drive number	0~65535	-	-	Stop setting and power on again	RW	Uint16
P01.50	2001	32	Software version number	-	-	-	-	RO	Uint16

8.2.2 2002 Group Object Dictionary (P02 Group Parameters)

function code	index	subindex	Name	Predetermined area	Unit	Factory set up	Setting takes effect	Attributes	Type
P02.00	2002	01	Control mode selection	9: EtherCAT Mode	-	9	The shutdown setting takes effect immediately	RO	Uint16
P02.01	2002	02	Encoder type selection	0: Incremental encoder 1: Absolute encoder	-	0	shutdown settings Power on again	RW	Uint16
P02.02	2002	03	Rotation direction selection	0: Take the CCW direction as the forward direction 1: Take the CW direction as the forward direction	-	0	shutdown settings Power on again	RW	Uint16
P02.03	2002	04	Output pulse phase	0: Take the CCW direction as the forward direction (A leads B) 1: Take the CW direction as the forward direction (A lags B)	-	0	shutdown settings Power on again	RW	Uint16
P02.05	2002	06	Servo enable OFF shutdown mode selection	0: Coast to stop, maintain free running state 1: Stop at zero speed and maintain free running state	-	0	The shutdown setting takes effect immediately	RW	Uint16
P02.07	2002	08	Overtravel stop mode selection	0: Coast to stop, maintain free running state 1: Stop at zero speed, the position remains locked 2: Stop at zero speed and maintain free running state	-	1	The shutdown setting takes effect immediately	RW	Uint16
P02.08	2002	09	Fault No.1 shutdown mode selection	0: Coast to stop, maintain free running state	-	0	The shutdown setting takes effect immediately	RW	Uint16
P02.09	2002	0A	Delay from brake output ON to command reception	0~500	ms	250	Run settings take effect immediately	RW	Uint16
P02.10	2002	0B	In static state, delay from brake output OFF to motor de-energization	1~1000	ms	150	Run settings take effect immediately	RW	Uint16
P02.11	2002	0C	Rotating state, speed threshold when brake output is OFF	0~3000	rpm	30	Run settings take effect immediately	RW	Uint16

P02.12	2002	0D	Rotating state, delay from servo enable OFF to brake output OFF	1~1000	ms	500	Run settings take effect immediately	RW	Uint16
P02.15	2002	10	LED warning display selection	0: Output warning information immediately 1: No warning message is output	-	0	The shutdown setting takes effect immediately	RW	Uint16
P02.21	2002	16	The minimum value of the braking resistor allowed by the driver	-	Ω	40	-	RO	Uint16
P02.22	2002	17	Built-in braking resistor power	-	W	50	-	RO	Uint16
P02.23	2002	18	Built-in braking resistor resistance	-	Ω	50	-	RO	Uint16
P02.24	2002	19	Resistor heat dissipation coefficient	10~100	%	30	The shutdown setting takes effect immediately	RW	Uint16
P02.25	2002	1A	Braking resistor settings	0: Use built-in braking resistor 1: Use external braking resistor and natural cooling 2: Use external braking resistor and forced air cooling 3: No braking resistor is needed, all depends on capacitor absorption.	-	0	The shutdown setting takes effect immediately	RW	Uint16
P02.26	2002	1B	External braking resistor power	1~65535	W	-	The shutdown setting takes effect immediately	RW	Uint16
P02.27	2002	1C	External braking resistor resistance	1~1000	Ω	-	The shutdown setting takes effect immediately	RW	Uint16
P02.31	2002	20	System parameter initialization	0: No operation 1: Restore factory values (except P00/P01 group) 2: Clear fault records	-	0	The shutdown setting takes effect immediately	RW	Uint16
P02.32	2002	21	Panel default display function	0~99, corresponding to the PB group parameter number, setting bit 0 corresponds to speed monitoring, setting bit 13 corresponds to pulse monitoring	-	50	Run settings take effect immediately	RW	Uint16

8.2.3 2003 Group Object Dictionary (P03 Group Parameters)

function code	index	subindex	Name	Predetermined area	Unit	Factory set up	Setting takes effect	Attributes	Type
P03.00	2003	01	DI function assignment effective at power on 1	Set the hexadecimal code (0000~FFFF) corresponding to the DI function (FunIN.1~FunIN.16). After the control power is turned on again, the DI function will be effective immediately.	-	0	Run Settings Power on again	RW	Uint16
P03.01	2003	02	DI function assignment effective at power on 2	Set the corresponding hexadecimal code (0000~FFFF) of the DI function (FunIN.17~FunIN.32). After the control power is turned on again, the DI function will be available immediately effect.	-	0	Run Settings Power on again	RW	Uint16
P03.02	2003	03	DIO terminal function selection	0~39, Refer to Chapter 4.5.1 for instructions	-	14	Run settings	RW	Uint16

							Downtime takes effect		
P03.03	2003	04	DI0 Terminal logic selection	Input polarity: 0~4 0. Indicates low level is active 1. Indicates that high level is effective 2. Indicates that the rising edge is valid 3. Indicates that the falling edge is valid 4 Indicates that both rising and falling edges are valid	-	0	Operation setting shutdown takes effect	RW	Uint16
P03.04	2003	05	DI1 Terminal function selection	0~39, Refer to Chapter 4.5.1 for instructions	-	15	Operation setting shutdown takes effect	RW	Uint16
P03.05	2003	06	DI1 Terminal function selection	Refer to P03.03 instructions	-	0	Operation setting shutdown takes effect	RW	Uint16
P03.06	2003	07	DI2 Terminal function selection	0~39, Refer to Chapter 4.5.1 for instructions	-	31	Operation setting shutdown takes effect	RW	Uint16
P03.07	2003	08	DI2 Terminal function selection	Refer to P03.03 instructions	-	0	Operation setting shutdown takes effect	RW	Uint16
P03.08	2003	09	DI3 Terminal function selection	0~39, Refer to Chapter 4.5.1 for instructions	-	0	Operation setting shutdown takes effect	RW	Uint16
P03.09	2003	0A	DI3 Terminal function selection	Refer to P03.03 instructions	-	0	Operation setting shutdown takes effect	RW	Uint16
P03.10	2003	0B	DI4 Terminal function selection	0~39, Refer to Chapter 4.5.1 for instructions	-	0	Operation setting shutdown takes effect	RW	Uint16
P03.11	2003	0C	DI4 Terminal function selection	Refer to P03.03 instructions	-	0	Operation setting shutdown takes effect	RW	Uint16
P03.34	2003	23	DI function assignment effective at power-on 3	Set the corresponding hexadecimal code (0000~FFFF) of the DI function (FunIN.33~FunIN.48). After the control power is turned on again, the DI function will be available immediately. effect.	-	0	Run Settings Power on again	RW	Uint16

8.2.4 2004 Group Object Dictionary (P04 Group Parameters)

function code	index	subindex	Name	Predetermined area	Unit	Factory set up	Setting takes effect	Attributes	Type
P04.00	2004	01	D00terminal function selection	0~20, Refer to Chapter 5.4.2	-	1	Operation setting shutdown takes effect	RW	Uint16
P04.01	2004	02	D00terminal logic selection	Output polarity reversal setting: 0~1 0. Indicates that the output is low level when it is valid (the optocoupler is turned on) 1. Indicates that the output is high level when valid (optocoupler is turned off)	-	0	Operation setting shutdown takes effect	RW	Uint16
P04.02	2004	03	D01terminal function selection	0~20, Refer to Chapter 5.4.2	-	5	Operation setting shutdown takes effect	RW	Uint16
P04.03	2004	04	D01terminal logic selection	Refer to P04.01 instructions	-	0	Operation setting shutdown takes effect Operation setting shutdown takes effect	RW	Uint16
P04.04	2004	05	D02 terminal function selection	0~20, Refer to Chapter 5.4.2	-	3	Operation setting shutdown takes effect	RW	Uint16
P04.05	2004	06	D02 terminal logic selection	Refer to P04.01 instructions	-	0	Operation setting shutdown takes effect	RW	Uint16
P04.22	2004	17	D0 source selection	Set whether the D0 function logic selected by the hardware D0 terminals (D01~D03) is determined by the actual status of the drive or communication settings.	-	0	Run settings take effect immediately	RW	Uint16

8.2.5 2005 Group Object Dictionary (P05 Group Parameters)

function code	index	subindex	Name	Predetermined area	Unit	Factory set up	Setting takes effect	Attributes	Type
P05.04	2005	05	First-order low-pass filter time constant	0~6553.5	ms	0.0	The shutdown setting takes effect immediately	RW	Uint16
P05.06	2005	07	Average filter time constant	0.0~128.0	ms	0.0	The shutdown setting takes effect immediately	RW	Uint16
P05.16	2005	11	Clear position deviation action selection	0~2	-	0	The shutdown setting takes effect immediately	RW	Uint16
P05.17	2005	12	Encoder frequency division pulse number	Set the number of pulses for one revolution of the motor.	Encoder unit	2500	Stop setting and power on again	RW	Uint16
P05.19	2005	14	Speed feed forward control selection	0. No speed feedforward 1. Internal speed feedforward 2Use 60B1 as speed feedforward	-	1	The shutdown setting takes effect immediately	RW	Uint16

P05.31	2005	20	Return to origin mode	direction	deceleration point	origin	Encoder unit	0	The shutdown setting takes effect immediately	RW	Uint16	
				0	forward	origin						origin
				1	reverse	origin						origin
				2	forward	Z signal						Z signal
				3	reverse	Z signal						Z signal
				4	forward	origin						Z signal
				5	reverse	origin						Z signal
				6	forward	Positive limit						Positive limit
				7	reverse	Negative limit						Negative limit
				8	forward	Positive limit						Z signal
9	reverse	Negative limit	Z signal									
				Set the default motor rotation, deceleration point, and origin when returning to zero.								
P05.35	2005	24	Limit the time to find the origin	0~65535			10ms	5000	Run settings take effect immediately	RW	Uint16	
P05.44	2005	2D	Encoder multi-turn data offset	0~65535			Encoder unit	0	shutdown settings Effective immediately	RW	Uint16	
P05.46	2005	2F	absolute position linear mode positionBias low 32-bit	-2147483648~2147483647			Encoder unit	0	shutdown settings Effective immediately	RW	Int32	
P05.48	2005	31	absolute position linear mode positionBias low 32-bit	-2147483648~2147483647			Encoder unit	0	shutdown settings Effective immediately	RW	Int32	
P05.50	2005	33	Absolute position rotation mode Mechanical gear ratio (numerator)	1~65535			-	1	shutdown settings Effective immediately	RW	Uint16	
P05.51	2005	34	Absolute position rotation mode Mechanical gear ratio (denominator)	1~65535			-	1	shutdown settings Effective immediately	RW	Uint16	

P05.52	2005	35	Absolute position rotation mode, rotation The number of pulses in one circle is the lower 32 bits	0~2147483647	Encoder unit	0	shutdown settings Effective immediately	RW	Uint32
P05.54	2005	37	Absolute position rotation mode, rotation The number of pulses in one circle is the lower 32 bits	0~127	Encoder unit	0	shutdown settings Effective immediately	RW	Uint32
P05.61	2005	3E	Position arrival threshold unit selection	0.Encoder unit 1. Command unit	-	1	shutdown settings Effective immediately	RW	Uint16

8.2.6 2006 Group Object Dictionary (P06 Group Parameters)

function code	index	subindex	Name	Predetermined area	Unit	Factory setup	Settings takes effect	Attributes	Type
P06.04	2006	05	Jog speed setting value	0~6000	rpm	100	Run settings take effect immediately	RW	Uint16
P06.11	2006	0C	Torque feedforward control selection	1. 1. Internal torque feedforward 2. 2Use 60B2 as external torque feedforward	-	1	Run settings take effect immediately	RW	Uint16
P06.15	2006	10	Zero position fixed speed threshold	0~6000; When the speed command amplitude is less than or equal to the 2006-10h setting value, the servo motor enters Zero position locked state	rpm	10	Run settings take effect immediately	RW	Uint16

8.2.7 2007 Group Object Dictionary (P07 Group Torque Control Parameters)

function code	index	subindex	Name	Predetermined area	Unit	Factory set up	Setting take effect	Attributes	Type
P07.05	2007	06	Torque command filter time constant	0~30.00	ms	0.79	Run settings take effect immediately	RW	Uint16
P07.06	2007	07	Second torque command filter time constant	0~30.00	ms	0.79	Run settings take effect immediately	RW	Uint16
P07.07	2007	08	Torque limit source	0. Positive and negative internal torque limits1. Positive and negative external torque limits2. EtherCAT positive and negative external torque limits3. The minimum value of the positive and negative external torque and the positive and negative external torque limit of EtherCAT is the torque limit (P-CL, N-CL)4. Positive and negative internal torque and EtherCAT positive and negative external torqueSwitching between partial torque limit (P-CL, N-CL)	-	2	Run settings take effect immediately	RW	Uint16
P07.09	2007	0A	Positive internal torque limit	0.0~300.0	%	300.0	Run settings take effect immediately	RW	Uint16



P07.10	2007	0B	Negative internal torque limit	0.0~300.0	%	300.0	Run settings take effect immediately	RW	Uint16
P07.11	2007	0C	Positive external torque limit	0.0~300.0	%	300.0	Run settings take effect immediately	RW	Uint16
P07.12	2007	0D	Negative external torque limit	0.0~300.0	%	300.0	Run settings take effect immediately	RW	Uint16
P07.15	2007	10	emergency stop torque	0.0~300.0	%	300.0	Run settings take effect immediately	RW	Uint16
P07.17	2007	12	Speed limit source selection	0: Internal speed limit 1: EtherCAT external speed limit 2: Select via FunIN.36 2007-14h/2007-15h as internal speed limit	-	0	Run settings take effect immediately	RW	Uint16
P07.19	2007	14	Torque control forward speed limit /Torque control speed limit 1	0~6000	rpm	3000	Run settings take effect immediately	RW	Uint16
P07.20	2007	15	Torque control negative speed limit/Torque control speed limit 2	0~6000	rpm	3000	Run settings take effect immediately	RW	Uint16
P07.21	2007	16	Torque reaches reference value	0.0~300.0	%	0.0	Run settings take effect immediately	RW	Uint16

P07.22	2007	17	Torque reaches effective value	0.0~300.0	%	20.0	Run settings take effect immediately	RW	Uint16
P07.23	2007	18	Torque reaches invalid value	0.0~300.0	%	10.0	Run settings take effect immediately	RW	Uint16
P07.40	2007	29	Speed limited window in torque mode	0.5~30.0	ms	1.0	Run settings take effect immediately	RW	Uint16

8.2.8 2008 Group Object Dictionary (P08 Group Gain Parameters)

function code	index	subindex	Name	Predetermined area	Unit	Factory set up	Setting takes effect	Attributes	Type
P08.00	2008	01	Speed loop gain	0.1~2000.0	Hz	25.0	Run settings take effect immediately	RW	Uint16
P08.01	2008	02	Speed loop integration time constant	0.15~512.00	ms	31.83	Run settings take effect immediately	RW	Uint16
P08.02	2008	03	Position loop gain	0.0~2000.0	Hz	40.0	Run settings take effect immediately	RW	Uint16
P08.03	2008	04	2nd speed loop gain	0.1~2000.0	Hz	40.0	Run settings take effect immediately	RW	Uint16
P08.04	2008	05	2nd speed loop integration time constant	0.15~512.00	ms	40.00	Run settings take effect immediately	RW	Uint16

P08.05	2008	06	2nd position loop gain	0.0~2000.0	Hz	64.0	Run settings take effect immediately	RW	Uint16
P08.08	2008	09	2nd gain mode setting	0. The first gain is fixed, use external DI for P/PI switching 1 Use gain switching according to the condition setting of P08.09	-	1	Run settings take effect immediately	RW	Uint16
P08.09	2008	0A	Gain switching condition selection	0. First gain fixed (PS) 1. Use external DI switching (PS) 2. Large torque command (PS) 3. Large speed command (PS) 4. Large change rate of speed command (PS) 5. Speed command high and low speed threshold (PS) 6. Large position deviation (P) 7. With position command (P) 8. Positioning completed (P) 9. High actual speed (P) 10. With position command + actual speed (P)	-	0	Run settings take effect immediately	RW	Uint16
P08.10	2008	0B	Gain switching delay time	0.0~1000.0	ms	5.0	Run settings take effect immediately	RW	Uint16

P08.11	2008	0C	Gain switching level	0~20000	According to switching conditions 	50	Run settings take effect immediately	RW	Uint16
P08.12	2008	0D	Gain switching time lag	0~20000	According to switching conditions 	30	Run settings take effect immediately	RW	Uint16
P08.13	2008	0E	Position gain switching time	0.0~1000.0	ms	3.0	Run settings take effect immediately	RW	Uint16
P08.15	2008	10	Load inertia ratio	0.00~120.00	倍	1.00	Run settings take effect immediately	RW	Uint16
P08.18	2008	13	Speed feedforward filter time constant	0.00~64.00	ms	0.50	Run settings take effect immediately	RW	Uint16
P08.19	2008	14	Speed feedforward gain	0.0~100.0	%	0.0	Run settings take effect immediately	RW	Uint16
P08.20	2008	15	Torque feedforward filter time constant	0.00~64.00	ms	0.50	Run settings take effect immediately	RW	Uint16
P08.21	2008	16	Torque feedforward gain	0.0~200.0	%	0.0	Run settings take effect immediately	RW	Uint16
P08.22	2008	17	Speed feedback filtering options	0. Disable speed feedback average filtering 1. Speed feedback 2 times average filtering 2. Speed feedback 4 times average filtering 3. Speed feedback 8 times average filtering 4. Speed feedback 16 times average filtering	-	0	The shutdown setting takes effect immediately	RW	Uint16
P08.23	2008	18	Speed feedback low-pass filter cutoff frequency	100~4000	Hz	4000	Run settings take effect immediately	RW	Uint16
P08.24	2008	19	Pseudo-differential	0.0~100.0	-	100.0	Run settings take	RW	Uint16

		feedforward control coefficient				effect immediately		
--	--	---------------------------------	--	--	--	--------------------	--	--

8.2.9 2009 Group Object Dictionary (P09 Group Self-tuning Parameters)

function code	index	sub index	Name	Predetermined area	Unit	Factory set up	Setting takes effect	Attributes	Type
P09.00	2009	01	Self-adjusting mode selection	0. Parameter self-adjustment is invalid, manually adjust the gain parameters; 1. Parameter self-adjusting mode, using the rigidity table to automatically adjust the gain parameters; 2. Positioning mode, use the rigidity table to automatically adjust the gain parameters; 3. Parameter self-adjusting mode with friction compensation; 4. Positioning mode with friction compensation	-	0	Run settings take effect immediately	RW	Uint16
P09.01	2009	02	Group 1 rigidity level selection	0~31	-	12	Run settings take effect immediately	RW	Uint16
P09.02	2009	03	Adaptive notch mode selection	0. The adaptive notch filter is no longer updated 1. Adaptive notches are effective (the third group of notches) 2.2 adaptive notches are effective (3rd and 4th set of notches) 3. Only test the resonance point, which is displayed in P09.24 4 Restore the values of the 3rd and 4th groups of notches to factory settings	-	0	Run settings take effect immediately	RW	Uint16
P09.03	2009	04	Online inertia identification mode	0. Turn off online inertia identification 1. Turn on online inertia identification and change slowly 2. Turn on online inertia identification, general changes 3 Turn on online inertia identification and change quickly				RW	Uint16

EtherCAT bus servo drive user manual

P09.04	2009	05	Low frequency resonance suppression mode selection	0. Manually set vibration frequency 1. Automatically identify vibration frequency	-	0	Run settings take effect immediately	RW	Uint16
P09.05	2009	06	Offline inertia identification mode selection	0. Positive and negative triangle wave mode 1. JOG jog mode	-	0	The shutdown setting takes effect immediately	RW	Uint16
P09.06	2009	07	Inertia identification maximum speed	100~1000	r p m	500	The shutdown setting takes effect immediately	RW	Uint16
P09.07	2009	08	Accelerate to the maximum during inertia identification speed time constant	20~800	m s	125	The shutdown setting takes effect immediately	RW	Uint16
P09.08	2009	09	Waiting time after completion of single inertia identification	50~10000	m s	800	The shutdown setting takes effect immediately	RW	Uint16
P09.09	2009	0A	Complete single inertia identification of motor Number of turns	0.00~2.00	r	-	-	RO	Uint16

P09.12	2009	0D	Group 1 notch frequency	50~4000	Hz	4000	Run settings take effect immediately	RW	Uint16
P09.13	2009	0E	Group 1 Notch Width Class	0~20	-	2	Run settings take effect immediately	RW	Uint16
P09.14	2009	0F	Group 1 Notch Depth Rating	0~99	-	0	Run settings take effect immediately	RW	Uint16
P09.15	2009	10	Group 2 notch frequency	50~4000	Hz	4000	Run settings take effect immediately	RW	Uint16
P09.16	2009	11	Group 2 Notch Width Class	0~20	-	2	Run settings take effect immediately	RW	Uint16
P09.17	2009	12	Group 2 Notch Depth Rating	0~99	-	0	Run settings take effect immediately	RW	Uint16
P09.18	2009	13	Group 3 notch frequency	50~4000	Hz	4000	Run settings take effect immediately	RW	Uint16
P09.19	2009	14	Group 3 Notch Width Class	0~20	-	2	Run settings take effect immediately	RW	Uint16
P09.20	2009	15	Group 3 Notch Depth Rating	0~99	-	0	Run settings take effect immediately	RW	Uint16
P09.21	2009	16	Group 4 notch frequency	50~4000	Hz	4000	Run settings take effect immediately	RW	Uint16
P09.22	2009	17	Group 4 Notch Width Class	0~20	-	2	Run settings take effect immediately	RW	Uint16
P09.23	2009	18	Group 4 Notch Depth Rating	0~99	-	0	Run settings take effect immediately	RW	Uint16
P09.24	2009	19	Resonance frequency identification results	0~2	Hz	0	-	RO	Uint16
P09.30	2009	1F	Torque disturbance compensation gain	0.0~100.0	%	0.0	Run settings take effect immediately	RW	Uint16
P09.31	2009	20	Torque disturbance observer filter time constant	0.00~25.00	ms	0.50	Run settings take effect immediately	RW	Uint16
P09.38	2009	27	low frequency resonance frequency	1.0~100.0	Hz	100.0	Run settings take effect immediately	RW	Uint16
P09.39	2009	28	Low frequency resonance frequency filter setting	0~10	-	2	Run settings take effect immediately	RW	Uint16

8.2.10 200A group object dictionary (POA group fault and protection parameters)

function code	index	sub index	Name	Predetermined area	Unit	Factory setup	Setting takes effect	Attributes	Type
POA.00	200A	01	Power input phase loss protection selection	0. Enable fault prohibition warning 1. Enable faults and warnings 2. Disable faults and warnings	-	0	Run settings take effect immediately	RW	Uint16
POA.01	200A	02	Absolute position limit settings	0. Disable absolute position limit 1. Enable absolute position limit 2. Enable absolute position limit after origin return	-	0	The shutdown setting takes effect immediately	RW	Uint16
POA.03	200A	04	Power-off save function enable selection	0. Do not perform power-off save 1. Execute power-off save	-	0	Run settings take effect immediately	RW	Uint16

POA. 04	200A	05	Motor overload protection gain	50~300	%	100	The shutdown setting takes effect immediately	RW	Uint 16
POA. 08	200A	09	Overspeed fault threshold	0: Max speed $\times 1.2$; 1~10000: 200A-09h~Max speed $\times 1.2$;	rpm	0	Run settings take effect immediately	RW	Uint 16
POA. 12	200A	0D	Overrun protection function enabled	0. No speed protection 1. Turn on speed protection	-	1	Run settings take effect immediately	RW	Uint 16
POA. 16	200A	11	Judgment of low frequency resonance position deviation threshold	1~1000	Encoder unit	5	Run settings take effect immediately	RW	Uint 16

EtherCAT bus servo drive user manual

POA. 25	200A	1A	Speed Feedback display value filter time constant	0~5000	ms	50	The shutdown setting takes effect immediately	RW	Uint 16
POA. 26	200A	1B	Motor overload shield enable	0. Open motor overload detection 1. Shield motor overload warning and fault detection	-	0	The shutdown setting takes effect immediately	RW	Uint 16
POA. 27	200A	1C	Speed DO filter time constant	0~5000	ms	10	The shutdown setting takes effect immediately	RW	Uint 16
POA. 28	200A	1D	Quadrature encoder filter time constant	0~255	25ns	30	shutdown settings Power on again	RW	Uint 16

POA.32	200A	21	Locked rotor over-temperature protection time window	10~65535	ms	200	Run settings take effect immediately	RW	Uint16
POA.33	200A	22	Stalled rotor over-temperature protection enabled	0. Shield motor stalled rotation over-temperature protection detection 1 Enable motor stall over-temperature protection detection	-	1	Run settings take effect immediately	RW	Uint16
POA.36	200A	25	Encoder multi-turn overflow fault selection	0. No shielding 1. Shield	-	0	The shutdown setting takes effect immediately	RW	Uint16

8.2.11 200B group object dictionary (POB group monitoring parameters)

For specific parameters, please refer to Chapter 5.1.6

8.2.12 200C group object dictionary (POC group communication parameters)

function code	index	subindex	Name	Predetermined area	Unit	Factory set up	Setting take effect	Attributes	Type
POC.00	200C	01	drive address	1~247	-	1	Run settings take effect immediately	RW	Uint16
POC.02	200C	03	Serial port baud rate setting	0. 2400 Kbp/s 1. 4800 Kbp/s 2. 9600 Kbp/s 3. 19200 Kbp/s 4. 38400 Kbp/s 5. 57600 Kbp/s	-	5	Run settings take effect immediately	RW	Uint16

POC.03	200C	04	MODBUS data format	0. No parity, 2 end bits 1. Even parity, 1 end bit 2. Odd parity, 1 end bit 3. No parity, 1 end bit	-	0	Run settings take effect immediately	RW	Uint16
POC.04	200C	05	Site name corrected	For the master station whose station number is automatically assigned, the station number assigned to the slave station when using EtherCAT communication is displayed.	-	-	-	RO	Uint16
POC.05	200C	06	site alias	For a master station that cannot automatically assign a station number, when using EtherCAT communication, set the slave station number through this object.	-	0	The shutdown setting takes effect immediately	RW	Uint16
POC.13	200C	0E	Whether the communication write function code value is updated to EEPROM	0. Do not save 1. 2000h series object dictionary is written and stored in EEPROM after communication 2. 6000h series object dictionary is written and stored in EEPROM after communication 3. The object dictionary of 2000h series and 6000h series is written and stored in EEPROM after communication.	-	0	Run settings take effect immediately	RW	Uint16
POC.35	200C	24	EtherCAT sync interrupt lost Disallowed times	4~20	1ms	9	Run settings take effect immediately	RW	Uint16
POC.36	200C	25	Port0 port CRC check error	0~65535	W	0	-	RO	Uint16

POC. 37	200C	26	Port1 port CRC check error error	0~65535	W	0	-	RO	Uint16
POC. 38	200C	27	Port 0, 1 data forwarding error	0~65535	W	0	-	RO	Uint16
POC. 39	200C	28	Processing unit and PDI errors	0~65535	W	0	-	RO	Uint16
POC. 40	200C	29	Port 0, 1 link lost	0~65535	W	0	-	RO	Uint16
POC. 42	200C	2B	Synchronization error monitoring mode setting	0~1	-	0	The shutdown setting takes effect immediately	RW	Uint16
POC. 43	200C	2C	Sync mode settings	0: The driver working sequence is asynchronous with the host computer synchronization clock. 1: Suitable for the host computer synchronization performance indicators to meet In the case of lus jitter (standard performance index of EtherCAT master station). 2: Suitable for host computer synchronization performance indicators exceeding In the case of lus jitter (standard performance indicator of EtherCAT master station)	-	2	The shutdown setting takes effect immediately	RW	Uint16

POC.44	200C	2D	Synchronization error threshold	0~2000: Used to set the jitter range of the synchronization signal allowed when the driver works in synchronization 1 mode (200C-2Ch=1).	1nm	500	The shutdown setting takes effect immediately	RW	Uint16
POC.45	200C	2E	Location cache settings	0: Disable location caching 1: Enable location cache	-	1	The shutdown setting takes effect immediately	RW	Uint16
POC.46	200C	2F	CSP position command increment excessive threshold	1~7; the counting threshold when the position command increment exceeds the maximum position command increment	-	3	Run settings take effect immediately	RW	Uint16
POC.47	200C	30	CSP position command increment too large times	0~65535; the count value when the position command increment exceeds the maximum position command increment threshold	-	0	-	RO	Uint16

8.2.13 200D group object dictionary (POD group auxiliary function parameters)

function code	index	sub index	Name	Predetermined area	Unit	Factory set up	Setting takes effect	Attributes	Type
POD.00	200D	01	software reset	0.No operation 1. Enable	-	0	The shutdown setting takes effect immediately	RW	Uint16
POD.01	200D	02	Fault reset	0.No operation 1. Enable	-	0	The shutdown setting takes effect immediately	RW	Uint16
POD.02	200D	03	Offline inertia identification function	-	-	-	Run settings take effect immediately	RW	Uint16
POD.03	200D	04	Initial angle recognition	1. Enable	-	-	-	RW	Uint16
POD.05	200D	06	Emergency shutdown	0.No operation 1. Enable emergency shutdown	-	0	Run settings take effect immediately	RW	Uint16

POD.11	200D	0C	JOG trial operation function	(comes with filter)	-	-	-	RW	Uint16
POD.17	200D	12	DIDO forced input and output enable	<p>0.No operation</p> <p>1. Force DI to be enabled and force DO to be disabled.</p> <p>2. Force DO to enable, force DI to disable</p> <p>3. Force DIDO to be enabled</p> <p>4. EtherCAT control forces DO to be enabled and forces DI to disable.</p>	-	0	Run settings take effect immediately	RW	Uint16
POD.18	200D	13	DI forced input given	0~0x01FF	-	0x01FF	Run settings take effect immediately	RW	Uint16
POD.19	200D	14	DO forces output given	0~0x001F	-	0	Run settings take effect immediately	RW	Uint16
POD.20	200D	15	Absolute encoder reset enable	<p>0.No operation</p> <p>1.Reset fault</p> <p>2. Reset fault and multi-turn data</p>	-	0	The shutdown setting takes effect immediately	RW	Uint16

8.3 6000 Group of object dictionary parameters

object dictionary	subindex	Name	scope	unit	Factory set up	Setting takes effect	Attributes	Type
603F	00	error code	0~65535	-	0	-	RO	Uint16
6040	00	control word	0~65535	-	0	Operation setting shutdown takes effect	RW	Uint16
6041	00	status word	0~xFFFF	-	0	-	RO	Uint16

605A	00	Quick shutdown mode selection choose	0~7; Refer to Appendix 1	-	2	Operation setting shutdown takes effect	RW	INT16
605D	00	Temporary shutdown method selection	1~3; Refer to Appendix 1	-	1	Operation setting shutdown takes effect	RW	INT16
6060	00	Servo mode selection	0~10; Refer to section 7.2.1	-	0	Operation setting shutdown takes effect	RW	INT8
6061	00	Run mode display	0~10	-	0	-	RO	INT8
6062	00	position command	-	command unit	-	-	RO	Dint32
6063	00	position feedback	-	Encoder unit	-	-	RO	Dint32
6064	00	position feedback	-	command unit	-	-	RO	Dint32

6065	00	Position deviation excessive threshold	0~2147483647	command unit	1048576	Operation setting shutdown takes effect	RW	UDint32
6067	00	Position reaches threshold	0~2147483647	Encoder unit	734	Operation setting shutdown takes effect	RW	UINT32
6068	00	Location arrival window time	0~65535	ms	16	Operation setting shutdown takes effect	RW	UINT16
606C	00	actual speed	-	command unit/S	-	-	RO	INT32
606D	00	speed reaches threshold	0~65535	rpm	10	Operation setting shutdown takes effect	RW	UINT16
606E	00	Speed arrival window time	0~65535	ms	0	Operation setting shutdown takes effect	RW	UINT16
6071	00	target torque	-4000~4000	0.1%	0	Operation setting shutdown takes effect	RW	UINT16
6072	00	Maximum torque command	0~4000	0.1%	5000	Operation setting shutdown takes effect	RW	UINT16

6074	00	Torque command	-5000~5000	0.1%	0	-	RO	INT16
6077	00	actual torque	-5000~5000	0.1%	0	-	RO	INT16
607A	00	target location	-2147483648~2147483647	command unit	0	Operation setting shutdown takes effect	RW	INT32
607C	00	Origin offset	-2147483648~2147483647	command unit	0	Operation setting shutdown takes effect	RW	INT32
607D	01	Minimum location limit	-2147483648~2147483647	user bit setting unit	-2^{31}	Operation setting shutdown takes effect	RW	INT32
607D	02	Maximum location limit	-2147483648~2147483647	user bit setting unit	2^{31}	Operation setting shutdown takes effect	RW	INT32
607E	00	Command polarity	Set the polarity of position command, speed command and torque command. Bit0~Bit4: Undefined; Bit5: Torque command polarity; Bit6: Speed command polarity; Bit7: Position command polarity; ON: Negate the command.	-	0	Operation setting shutdown takes effect	RW	UINT8
607F	00	Maximum speed	0~2147483647	command unit/S	104857600	Operation setting shutdown takes effect	RW	UINT32

6081	00	Contour running speed	0~2147483647	User speed unit	0	Operation setting shutdown takes effect	RW	UINT32
6083	00	Profile acceleration	0~2147483647	command unit/S ²	100000	Operation setting shutdown takes effect	RW	UINT32
6084	00	Profile deceleration	0~2147483647	command unit/S ²	100000	Operation setting shutdown takes effect	RW	UINT32
6085	00	Emergency stop deceleration	0~2147483647	command unit/S ²	100000	Operation setting shutdown takes effect	RW	UINT32
6086	00	Operating curve selection	0-Linear	-	0	-	RW	INT16
6087	00	Torque ramp	0~2147483647	0.1%/S	2 ³² -1	Operation setting shutdown takes effect	RW	UINT32
6091	01	Motor resolution	1~2147483647	-	1	Run settings take effect immediately	RW	UINT32

6091	02	Axis resolution	1~2147483647	-	1	Run settings take effect immediately	RW	UINT32
6098	00	Zero return method	1~35; Refer to Appendix 2 for return to zero mode.	-	0	Operation setting shutdown takes effect	RW	INT8
6099	01	Return to Zero Expressway	0~2147483647	command unit/S	131072	Operation setting shutdown takes effect	RW	UINT32
6099	02	Return to zero low speed	10~2147483647)	command unit/S	13107	Operation setting shutdown takes effect	RW	INT32
609A	00	Return to zero acceleration	0~2147483647	command unit/S ²	100000	Operation setting shutdown takes effect	RW	DUINT32
60B0	00	position offset	-2147483648~2147483647	command unit	0	Operation setting shutdown takes effect	RW	INT32
60B1	00	speed bias	-2147483648~2147483647	command unit/S	0	Operation setting shutdown takes effect	RW	INT32

60B2	00	Torque bias	-5000~5000	0.1%	0	Operation setting shutdown takes effect	RW	INT16
60B8	00	probe mode	0~65535	-	0	Operation setting shutdown takes effect	RW	UINT16
60B9	00	Probe status	0~65535	-	0	-	RO	UINT16
60BA	00	Probe 1 rising edge position value	-2147483648~2147483647	command unit	0	-	RO	INT32
60BB	00	Probe 1 falling edge position value	-2147483648~2147483647	command unit	0	-	RO	INT32
60BC	00	Probe 2 rising edge position value	-2147483648~2147483647	command unit	0	-	RO	INT32
60BD	00	Probe 2 falling edge position value	-2147483648~2147483647	command unit	0	-	RO	INT32
60E0	00	Forward torque limit	0~5000	0.1%	5000	Operation setting shutdown takes effect	RW	UINT16
60E1	00	Reverse torque limit	0~5000	0.1%	5000	Operation setting shutdown takes effect	RW	UINT16
60E3	01 ~ 1F	Supported zero return method 1~Supported zero return method 31	bit0~bit7: The lower 8 bits are used to display the supported zero return method. Bit8: Whether to support relative position zero return Bit9: Whether to support absolute position zero return	-	-	-	RO	UINT16
60E6	00	Actual position calculation method	0: Absolute position return to zero. After the origin return is completed, position feedback 6064 is set to origin offset 607Ch; 1: Relative position return to zero. After the origin return is completed, the position feedback 6064 will superimpose the position offset 607Ch on the original basis.	-	0	Operation setting shutdown takes effect	RW	UINT8
60F4	00	position deviation	Display position deviation	command unit	-	-	RO	DINT32

60FC	00	position command	Position command 60FC (encoder unit) = position command 6062 (command unit) × electronic gear ratio (6091)	Encoder unit	-	-	RO	DINT32																								
60FD	00	DI state	<table border="1"> <tr> <th>Bit</th> <th>2</th> </tr> <tr> <td>0</td> <td>Reverse overtravel switch</td> </tr> <tr> <td>1</td> <td>Forward overtravel switch</td> </tr> <tr> <td>2</td> <td>Origin switch</td> </tr> <tr> <td>16</td> <td>Z Signal</td> </tr> <tr> <td>17</td> <td>probe 1</td> </tr> <tr> <td>18</td> <td>probe 2</td> </tr> <tr> <td>20</td> <td>DI0</td> </tr> <tr> <td>21</td> <td>DI1</td> </tr> <tr> <td>22</td> <td>DI2</td> </tr> <tr> <td>23</td> <td>DI3</td> </tr> <tr> <td>24</td> <td>DI4</td> </tr> </table>	Bit	2	0	Reverse overtravel switch	1	Forward overtravel switch	2	Origin switch	16	Z Signal	17	probe 1	18	probe 2	20	DI0	21	DI1	22	DI2	23	DI3	24	DI4	-	0	-	RO	DINT32
Bit	2																															
0	Reverse overtravel switch																															
1	Forward overtravel switch																															
2	Origin switch																															
16	Z Signal																															
17	probe 1																															
18	probe 2																															
20	DI0																															
21	DI1																															
22	DI2																															
23	DI3																															
24	DI4																															
60FE	01	physical output	Bit0 of 60FE-01h: brake output; when 200D-12h=4, the DO output is controlled by the bits of 60FE-01h and 60FE-02h:	-	0	Operation setting shutdown takes effect	RW	UINT32																								
60FE	02	Physical output enable	<table border="1"> <thead> <tr> <th></th> <th>60FE-01h</th> <th>60FE-02h</th> </tr> </thead> <tbody> <tr> <td>DO0</td> <td>Bit16</td> <td>Bit16</td> </tr> <tr> <td>DO1</td> <td>Bit17</td> <td>Bit17</td> </tr> <tr> <td>DO2</td> <td>Bit18</td> <td>Bit18</td> </tr> </tbody> </table>		60FE-01h	60FE-02h	DO0	Bit16	Bit16	DO1	Bit17	Bit17	DO2	Bit18	Bit18	-	0	Operation setting shutdown takes effect	RW	UINT32												
	60FE-01h	60FE-02h																														
DO0	Bit16	Bit16																														
DO1	Bit17	Bit17																														
DO2	Bit18	Bit18																														
60FF	00	target speed	-2147483648~2147483647	command unit/S	0	Operation setting shutdown takes effect	RW	INT32																								

Chapter 9 Troubleshooting

9.1 Fault and warning code table

9.1.1 Fault code table (to reset the fault, you need to cancel the enable first)

Display	Error code (603Fh)	Warning name	Reset	Warning phenomena and treatment methods
Er.101	0x6320	P02 and above group parameter abnormality	no	1. If the function code parameter value of group P02 and subsequent groups exceeds the upper and lower limits, re-initialize the parameters; 2. If the power is lost during the process of writing parameters, the parameters will be rewritten after powering on; 3. Reset the motor model and driver model, and initialize the parameters; 4. The drive EEPROM is abnormal, replace the drive.
Er.102	0x7500	Programmable logic configuration failure	no	MCU related hardware is damaged, replace the driver.
Er.104	0x7500	Programmable logic interrupt fault	no	MCU related hardware is damaged, replace the driver
Er.105	0x6320	Internal program exception	no	1. When EEPROM reads/writes function codes, the total number of function codes is abnormal and the parameters are initialized; 2. The range of the function code setting value is abnormal, and the parameters are initialized; 3. Initialize and power on again. If the alarm still occurs, replace the driver.
Er.108	0x5530	Parameter storage failure	no	1. Unable to write parameter values to EEPROM and initialize parameters; 2. Initialize and power on again. If the alarm still occurs, replace the driver.
Er.111	0x6320	Internal failure	no	Initialize and power on again. If the alarm still occurs, replace the driver.
Er.120	0x7122	Product matching failure	no	The motor model and driver model match incorrectly. Please contact after-sales personnel to check the motor model.
Er.121	0x5441	Servo ON command invalid fault	yes	DI port parameter configuration failure, recheck the DI function and VDI function configuration
Er.122	0x7122	Absolute position mode product matching failure	no	The absolute value motor model does not match, or the motor model is set incorrectly. Please contact after-sales personnel to check the motor model.
Er.130	0x6320	DI function duplicate assignment	yes	DI port parameter configuration failure, recheck the DI function and VDI function configuration or initialization parameters.
Er.131	0x6320	DO function allocation exceeded	yes	The DO function number exceeds the number of DO functions. Recheck the DO function configuration or initialization parameters.
Er.136	0x7305	The data in the motor ROM is checked incorrectly or the parameters are not stored.	no	When the driver reads the parameters in the encoder ROM area, it finds that the parameters are not stored, or the parameters are inconsistent with the agreed values. 1. Check the motor model and driver model; 2. Check whether the motor encoder line is correct and check whether the connector is reliably connected;

				3. Check whether the encoder line receives interference and rewire it.
Er.201	0x2312	Overcurrent 2	no	Hardware detects overcurrent; 1. Check whether the motor power wire U V W is connected correctly and whether there is any reverse connection or phase loss; 2. There is a short circuit in the U V W wire, or there is leakage in the connection between the motor coil and the shell. Replace the motor wire or test the motor; 3. Caused by poor contact of the encoder wire, check or replace the encoder wire; 4. The load is too heavy, first test the motor without load to see if it is normal; 5. The acceleration and deceleration are too fast, increase the acceleration and deceleration time of the program; 6. If the gain parameters have been adjusted, check whether the gain is set too high, reduce the gain and then test; 7. If the braking resistor is too small or short-circuited, use the internal braking resistor to test first; 8. The drive is damaged, replace the drive;
Er.207	0x0FFF	D/Q axis current overflow fault	yes	Abnormal current feedback causes the internal register of the driver to overflow. Replace the driver;
Er.208	0x0FFF	System sampling operation timed out	no	1. MCU communication timeout, replace the driver 2. Encoder communication times out, check whether the encoder cable is connected properly, or replace the encoder and reconnect it; 3. The motor encoder is faulty, replace the motor and test; 4. The current sampling times out, check whether there is any interference from large equipment on site, add an isolation transformer, and re-wiring; 5. When the high-precision AD conversion times out, check the analog input wiring to see if there is any interference, and connect it with a shielded wire; 6. The drive is damaged, replace the drive;
Er.210	0x2330	Output circuit short to ground	no	During the power-on self-test of the driver, an abnormality in the motor phase current or bus voltage was detected. 1. The power line U V W is short-circuited to the ground, check the motor line; 2. The motor coil is short-circuited to the casing, replace the motor; 3. The drive fails. Replace the drive.
Er.220	0x0FFF	Phase sequence error	no	The driver performs angle identification and finds that the phase sequence of the driver UVW and the motor UVW does not match. 1. The electrical angle of the motor encoder does not match, reset the motor parameters and perform self-learning; 2. The U V W phase sequence is reversed, so check the motor power line;
Er.234	0x0FFF	Motor stalls	no	In the torque control mode, the direction of the torque command is opposite to the direction of the speed feedback; or in the position or speed control mode, the direction of the speed feedback is opposite to the speed command; 1. The U V W phase sequence is reversed, so check the motor power line; 2. Interference signals cause the initial phase detection of the motor rotor to be incorrect. Power on again and check the wiring; 3. The encoder model is wrong or the wiring is wrong. Replace the motor or encoder wire; 4. Driver failure, replace the driver;

Er.400	0x3210	Main circuit electrical overvoltage	yes	DC bus voltage exceeds fault value 420V 1. Measure the power supply voltage. If the grid voltage is too high or unstable, a voltage regulator needs to be added; 2. The braking resistor fails. When the power is completely cut off, measure the resistance between driver B1 and B3. If it is infinite, the internal braking resistor is damaged and the driver needs to be replaced; 3. The resistance of the braking resistor is too large. Replace it with a 40 ohm or 50 ohm braking resistor. Please contact after-sales personnel; 4. The grid voltage is high, and the motor accelerates and decelerates too fast, increase the acceleration and deceleration time; 5. Monitor P0B-26 to see if the bus voltage matches the grid voltage. If the difference is too large, the driver may be damaged and the driver needs to be replaced. The corresponding bus voltage of 220V AC is 310V.
Er.410	0x3220	Main circuit electrical undervoltage	yes	The DC bus voltage is 200V lower than the fault value 1. The main circuit power supply is unstable or loses power. Recheck the wiring or add a voltage regulator; 2. Monitor P0B-26 to see if the bus voltage matches the grid voltage. If the difference is too large, the driver may be damaged and the driver needs to be replaced. The corresponding bus voltage of 220V AC is 310V.
Er.420	0x3130	Main circuit electrical phase loss	yes	The servo drive is faulty, replace the drive.
Er.430	0x3120	Control voltage undervoltage	yes	The servo drive is faulty, replace the drive.
Er.500	0x8400	speed alarm	yes	The actual speed of the servo motor exceeds the overspeed fault threshold 1. The U V W phase sequence of the motor cable is wrong, check the motor wiring; 2. The motor parameters are incorrect. Reset the motor parameters and perform self-learning; 3. The input command exceeds the overspeed fault threshold; 4. The motor speed is overshooting and the gain parameter setting is unreasonable. Test after initializing the driver parameters; 5. Driver failure, replace the driver.
Er.510	0x0FFF	Pulse output too fast	yes	The output pulse frequency exceeds the frequency upper limit allowed by the hardware Reduce P05-17 (encoder frequency division pulse number) so that the output pulse frequency is less than the allowed frequency upper limit.
Er.602	0x0FFF	Angle recognition failed	yes	The motor self-learning fails. Check whether the encoder cable is normal and whether the encoder type is correct.
Er.610	0x3230	Drive overload	yes	1. The motor model or driver model is set incorrectly. Please contact after-sales personnel to check the parameters; 2. Monitor the drive load rate PB-02 to see if overload causes an alarm; 3. If the motor is stalled, first rule out the motor stall condition before testing, or remove the motor and test without load;
Er.620	0x3230	Motor overload	yes	4. The gain parameter setting is too large, test after initializing the parameters; 5. The motor accelerates and decelerates too fast, increase the acceleration and deceleration time; 6. The motor cable U V W phase sequence is wrong, check the motor wiring; 7. The drive is damaged, replace the drive.

Er.630	0x7121	Motor stalled and overheated	yes	<p>The actual motor speed is lower than 10rpm, but the torque command reaches the limit value and the duration reaches the P0A-32 setting value.</p> <ol style="list-style-type: none"> 1. The UVW output of the driver is missing phase, disconnected, or the phase sequence is incorrectly connected; 2. The motor parameters are incorrect. Reset the motor parameters and perform self-learning; 3. If the motor is stalled, first rule out the motor stall condition before testing, or remove the motor and test without load;
Er.650	0x4210	Radiator overheated	yes	<p>The temperature of the drive power module is higher than the over-temperature protection point. The servo drive is faulty. Replace the drive.</p>
Er.731	0x7305	Encoder battery failure	yes	<p>The encoder battery voltage of the absolute encoder is lower than 3.0V,</p> <ol style="list-style-type: none"> 1. If the encoder line is disconnected, set P0D-20=2, then set P0D-01=1 to clear the fault; 2. The battery is dead, replace the battery.
Er.733	0x7305	Encoder multiturn count error	yes	<p>Initialize driver parameters, reset motor parameters and driver parameters, set encoder type, Then set P0D-20=2 and P0D-01=1 to clear the fault and power on again. If the alarm still occurs, replace the motor and test.</p>
Er.735	0x7305	Encoder multi-turn count overflow	yes	<p>Initialize driver parameters, reset motor parameters and driver parameters, set encoder type, Then set P0D-20=2 and P0D-01=1 to clear the fault and power on again. If the alarm still occurs, replace the motor and test.</p>
Er.740	0x7305	Encoder interference	no	<p>The encoder Z signal is interfered, causing the electrical angle corresponding to the Z signal to change too large.</p> <ol style="list-style-type: none"> 1. The encoder wiring is wrong or the connector is loose. Check or replace the encoder wire and then test; 2. The encoder Z signal is interfered, rewiring and ensure good grounding; 3. Encoder failure, replace the motor;
Er.A33	0x7305	Encoder data abnormality	no	<p>Encoder internal parameter abnormality</p> <ol style="list-style-type: none"> 1. The serial encoder cable is disconnected or loose. Check or replace the encoder cable for testing; 2. Encoder failure, replace the motor.
Er.A34	0x7305	Encoder feedback verification exception	no	<ol style="list-style-type: none"> 1. The driver and motor types do not match, reset the motor model; 2. The encoder cable is disconnected, check the encoder cable.
Er.A35	0x7305	Z signal lost	no	<p>Encoder Z signal is lost or AB signal edges jump at the same time</p> <ol style="list-style-type: none"> 1. The serial encoder cable is disconnected or loose. Check or replace the encoder cable for testing; 2. Encoder failure, replace the motor.
Er.B00	0x8611	Position deviation is too large	yes	<p>In position control mode, the position deviation is greater than the P0A-10 setting value</p> <ol style="list-style-type: none"> 1. The driver U V W output phase is missing or the phase sequence is wrongly connected, check the motor wire; 2. If the motor is stalled, first rule out the motor stall condition before testing, or remove the motor and test without load; 3. The gain of the servo driver is low, so test after initializing the parameters; 4. The position command increment is too large; 5. Whether the position deviation fault value 6065h is set too small; 6. The torque limit value is set too small, test after initializing the parameters; 7. Servo driver/motor failure, replace the driver or motor.

Er.B01	0x0FFF	Position command too large	yes	1. Is the position deviation fault value 6065h set too small? 2. Before mode switching or when servo is enabled, the target position (607A target position) is not aligned with the current position; 3. Synchronization cycle phase crossover leads to excessive position command accumulation; 4. Motor speed limit error;
Er.B03	0x6320	Electronic gear ratio setting exceeds limit	yes	1. The gear ratio 6091-01h/6091-02h exceeds the limit value; 2. Parameter change order problem;
Er.D09	0x6320	Software position upper and lower limit setting error	yes	The software position upper and lower limit settings are wrong, check 0x607D-01h and 0x607D-02h
Er.D10	0x6320	Origin offset setting error	yes	The origin offset is outside the upper and lower limits of the software position, check 0x607D-01h, 0x607D-02h, 0x607Ch
Er.E07	0x0FFF	Abnormal network status switching	yes	Check whether the network port is normal and whether the communication line is normal;
Er.E08	0x0FFF	Sync lost	yes	1. The slave station receives abnormally, check whether the network port is normal and whether the communication line is normal; 2. The master station sends abnormally, and the upper computer synchronization clock error is too large. You can try increasing 200E-21h;
Er.E11	0x0FFF	XML configuration file not burned	yes	1. The device configuration file is not burned; 2. Drive failure;
Er.E12	0x0E12	Network initialization failed	yes	1. The device configuration file is not burned; 2. Drive failure;
Er.E13	0x0E13	Synchronization cycle setting error	yes	Check whether the synchronization period is 125us or an integer multiple of 250us
Er.E15	0x0E15	Synchronization cycle error is too large	yes	1.XML files do not match; 2. The controller synchronization cycle error is large;

9.1.2 Warning code table (warnings can be reset directly without canceling the enable)

Display	Error code (603Fh)	Warning name	Reset	Warning phenomena and treatment methods
Er.110	0x6320	Frequency division pulse output setting failure	yes	The number of encoder frequency-divided pulses does not meet the range, reset the encoder frequency-divided pulse number (2005-12h);
Er.601	0x0FFF	Failed to return to origin	yes	1. Origin switch failure; 2. The time limit for searching the origin is too short; 3. The speed of high-speed search for origin switch signal is too small; 4. The switch setting is unreasonable;
Er.730	0x7305	Encoder battery warning	yes	The encoder battery voltage of the absolute encoder is lower than 3.0V. Replace the battery with a new one with matching voltage while the power is on.
Er.900	0x5442	DI emergency brake	yes	The corresponding DI terminal of DI function 34 (FunIN.34: Brake, Emergency) is triggered (including hardware DI and virtual DI), check the DI wiring.

Er.909	0x3230	Motor overload warning	yes	The load rate is too high, causing a warning. Check whether the load is too heavy or blocked.
Er.920	0x3210	Braking resistor overload	yes	Warning of excessive braking resistor current, 1. If the bus voltage is too high, causing energy to be discharged too quickly, a warning will appear. Add a voltage regulator to reduce the voltage; 2. Whether the motor decelerates too fast, increase the deceleration time; 3. The internal braking resistor has insufficient power. Replace the external braking resistor. It is recommended that the resistance value should not be lower than 40 ohms; 4. When using an external resistor, check the parameter values of P02-25 ~ P2-27, and set the value of P2-27 to be consistent with the resistance value of the selected resistor; 4. The driver braking circuit is damaged, replace the driver;
Er.922	0x6320	External braking resistor is too small	yes	P02-27 (resistance value of external braking resistor) is smaller than P02-21 (minimum value of external braking resistor allowed by the driver)
Er.939	0x3331	Motor power line is broken	yes	The actual phase current of the motor is less than 10% of the rated current, and the actual speed is small, but the internal torque command is large. Check the motor power cable wiring, rewire it, and replace the cable if necessary.
Er.941	0x6320	Parameter changes need to be powered on again to take effect.	yes	When the function code attribute "validity time" of the servo drive is "power on again", after the function code parameter value is changed, the drive reminds the user that he needs to power on again.
Er.942	0x7600	Parameters are stored frequently	yes	If the number of function codes modified at the same time exceeds 200, check the operating mode. For parameters that do not need to be stored in EEPROM, set P0C-13 to 0 before the host computer writes the operation.
Er.950	0x5443	Forward overtravel warning	yes	The corresponding DI terminal of DI function 14 (FunIN.14: P-OT, forward overtravel switch) is triggered.
Er.952	0x5444	Reverse overtravel warning	yes	The corresponding DI terminal of DI function 15 (FunIN.15: N-OT, reverse overtravel switch) is triggered.
Er.980	0x7305	Encoder internal fault	yes	If a fault still occurs after turning on the power several times, the encoder is faulty.
Er.990	0x3130	Input phase loss warning	yes	Driver power supply circuit failure;
Er.998	0x0FFF	Zero return mode setting error	yes	When using the zero return mode, 6098h inputs non-existent zero return modes such as 15/16/31/32.
Er.A40	0x0FFF	Internal failure	yes	Motor self-learning failed, 1. Check the motor encoder line error; 2. The encoder model is incorrect. Reset the motor model and encoder type; 3. The motor encoder is faulty, replace the motor.

Appendix 1 Shutdown method

Object dictionary	Subindex	Name	Scope	Unit	Factory settings	Setting take effect	Attributes	type			
605 A	00	Quick Shut Down Mode Selection	PP model:								
			set value	shutdown mode							
			0	Free stop and maintain free running status							
			1	Stop at 6084h ramp and maintain free running status							
			2	Stop at 6085h ramp and maintain free running status							
			3	Stop with 2007-10h emergency stop torque and maintain free running state							
			5	Stop at 6084h ramp and maintain position locked state							
			6	Stop at 6085h ramp and maintain position locked state							
			7	Stop with 2007-10h emergency stop torque and maintain position locked state							
				CSP model:							
			set value	shutdown mode							
			0	Free stop and maintain free running status							
			1	Stop with 2007-10h emergency stop torque and maintain free running state							
			2								
			3								
			5	Stop with 2007-10h emergency stop torque and maintain position locked state							
			6								
			7								
				CSV/PV/HM model:							
			set value	shutdown mode							
			0	Free stop and maintain free running status							
			1	Stop at 6084h (HM: 609Ah) ramp and maintain free running status							
			2	Stop at 6085h ramp and maintain free running status							
			3	Emergency stop torque to stop and maintain free running state							
			5	Stop at 6084h (HM: 609Ah) slope and maintain position locked state							
			6	Stop at 6085h ramp and maintain position locked state							
			7	Stop with 2007-10h emergency stop torque and maintain position locked state							
				CST/PT model:							
			set value	shutdown mode							
			0	Free stop and maintain free running status							
			1	Stop at 6087h ramp and maintain free running status							
			2								
			3	Free stop and maintain free running status							
			5	Stop at 6087h ramp and maintain position locked state							
			6								
			7	Coast to stop and maintain position lock state							
							-	2	Run settings Downtime take effect	RW	INT16

605 D	00	Temporarily Shutdown Method selection	PP model:	-	1	Run settings Downtime Takes effect	RW	INT1 6								
			<table border="1"> <thead> <tr> <th>set value</th> <th>shutdown mode</th> </tr> </thead> <tbody> <tr> <td>1</td> <td>Stop at 6084h ramp and maintain free running status</td> </tr> <tr> <td>2</td> <td>Stop at 6085h ramp and maintain free running status</td> </tr> <tr> <td>3</td> <td>Stop with 2007-10h emergency stop torque and maintain free running state</td> </tr> </tbody> </table>						set value	shutdown mode	1	Stop at 6084h ramp and maintain free running status	2	Stop at 6085h ramp and maintain free running status	3	Stop with 2007-10h emergency stop torque and maintain free running state
			set value						shutdown mode							
			1						Stop at 6084h ramp and maintain free running status							
2	Stop at 6085h ramp and maintain free running status															
3	Stop with 2007-10h emergency stop torque and maintain free running state															
CSP model	<table border="1"> <thead> <tr> <th>set value</th> <th>shutdown mode</th> </tr> </thead> <tbody> <tr> <td>1</td> <td rowspan="3">Stop with 2007-10h emergency stop torque and maintain free running state</td> </tr> <tr> <td>2</td> </tr> <tr> <td>3</td> </tr> </tbody> </table>	set value	shutdown mode	1	Stop with 2007-10h emergency stop torque and maintain free running state	2	3									
set value	shutdown mode															
1	Stop with 2007-10h emergency stop torque and maintain free running state															
2																
3																
CSV/PV/HM model	<table border="1"> <thead> <tr> <th>set value</th> <th>shutdown mode</th> </tr> </thead> <tbody> <tr> <td>1</td> <td>Stop at 6084h (HM: 609Ah) ramp and maintain free running status</td> </tr> <tr> <td>2</td> <td>Stop at 6085h ramp and maintain free running status</td> </tr> <tr> <td>3</td> <td>Emergency stop torque to stop and maintain free running state</td> </tr> </tbody> </table>	set value	shutdown mode	1	Stop at 6084h (HM: 609Ah) ramp and maintain free running status	2	Stop at 6085h ramp and maintain free running status	3	Emergency stop torque to stop and maintain free running state							
set value	shutdown mode															
1	Stop at 6084h (HM: 609Ah) ramp and maintain free running status															
2	Stop at 6085h ramp and maintain free running status															
3	Emergency stop torque to stop and maintain free running state															
			CST/PT model													
			<table border="1"> <thead> <tr> <th>set value</th> <th>shutdown mode</th> </tr> </thead> <tbody> <tr> <td>1</td> <td>Stop at 6087h ramp and maintain free running status</td> </tr> <tr> <td>2</td> <td>status</td> </tr> <tr> <td>3</td> <td>Free stop and maintain free running status</td> </tr> </tbody> </table>	set value	shutdown mode	1	Stop at 6087h ramp and maintain free running status	2	status	3	Free stop and maintain free running status					
set value	shutdown mode															
1	Stop at 6087h ramp and maintain free running status															
2	status															
3	Free stop and maintain free running status															

Appendix 2 Servo zero return method

6098=1: Reference negative limit and return-to-origin mode of Z-phase signal

Situation 1: The negative limit is invalid when starting to return to zero, and the axis starts to return to zero at high speed in the negative direction. When encountering the rising edge of the negative limit, the motor decelerates and runs in the positive direction at low speed. When encountering the negative limit, it decreases. The position of the first Z pulse after the edge is the origin position.

Situation 2: The negative limit is valid when starting to return to zero, and the axis begins to return to zero in the positive direction at low speed. When encountering the negative limit falling edge, the position of the first Z pulse is the origin position.

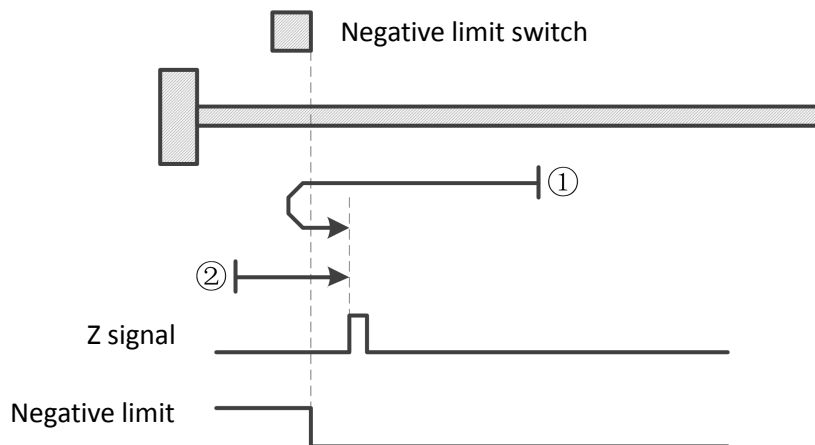

6098=2: Reference positive limit and Z-phase signal return-to-origin mode

Situation 1: The positive limit is invalid when starting to return to zero, and the axis begins to return to zero at high speed in the positive direction. When encountering the rising edge of the positive limit, the motor decelerates and runs in the negative direction at low speed. When encountering the positive limit The position of the first Z pulse after the falling edge is the origin position.

Scenario 2: The positive limit is valid when starting to return to zero, and the axis begins to return to zero in the negative direction at a low speed. When encountering the falling edge of the positive limit, the position of the first Negative limit origin position.

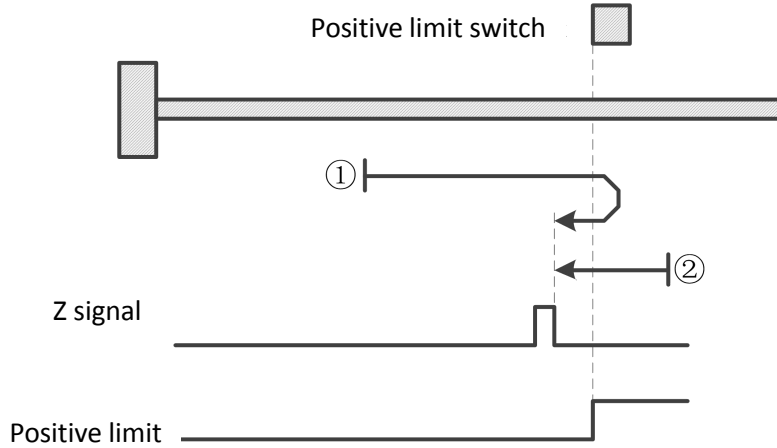

6098=3: Reference origin switch and forward return-to-origin mode of Z-phase signal

Situation 1: When starting the zero return, the origin signal is invalid, and the axis begins to return to zero at high speed in the positive direction. When encountering the rising edge of the origin, the motor decelerates and runs in the negative direction at low speed. When encountering the falling edge of the origin, the motor The position of one Z pulse is the origin position.

Situation 2: When the zero return is started, the origin signal is valid, and the axis begins to return to zero in the negative direction at a low speed. When it encounters the falling edge of the origin, the position of the first Z pulse is the origin position.

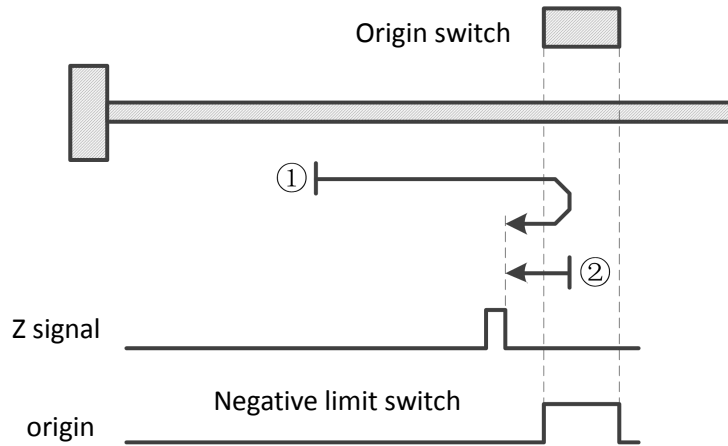

6098=4: Reference origin switch and forward return-to-origin mode of Z-phase signal

Situation 1: When starting the zero return, the origin signal is invalid, and the axis begins to return to zero in the positive direction at high speed. When encountering the rising edge of the origin, the motor decelerates and runs at low speed. The position when encountering the first Z pulse is the origin position.

Situation 2: When the zero return is started, the origin signal is valid, and the axis starts to return to zero at a low speed in the negative direction. When it encounters the falling edge of the origin, it decelerates and runs in the positive direction at a low speed. When it encounters the first rising edge of the origin, The position of the Z pulse is the origin position.

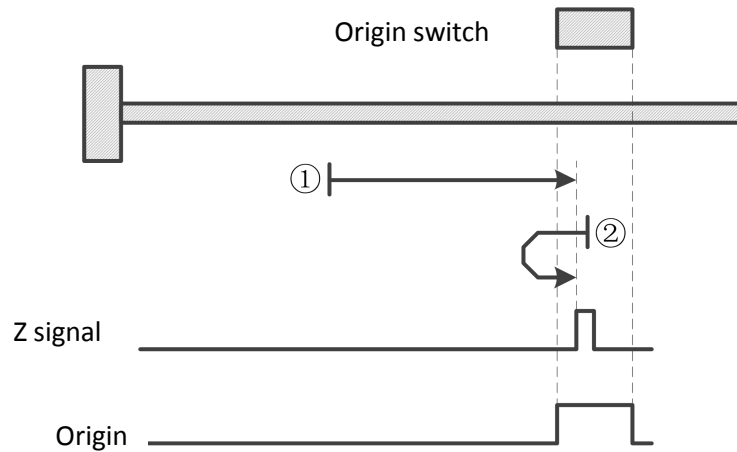

6098=5: Negative return-to-origin mode of reference origin switch and Z-phase signal

Situation 1: When the zero return is started, the origin signal is invalid, and the axis starts to return to zero at high speed in the negative direction. When encountering the rising edge of the origin, the motor decelerates and runs in the positive direction at low speed. When encountering the falling edge of the origin, the motor The position of one Z pulse is the origin position.

Situation 2: When the zero return is started, the origin signal is valid, and the axis begins to return to zero at a low speed in the positive direction. The position of the first Z pulse after encountering the falling edge of the origin is the origin position.

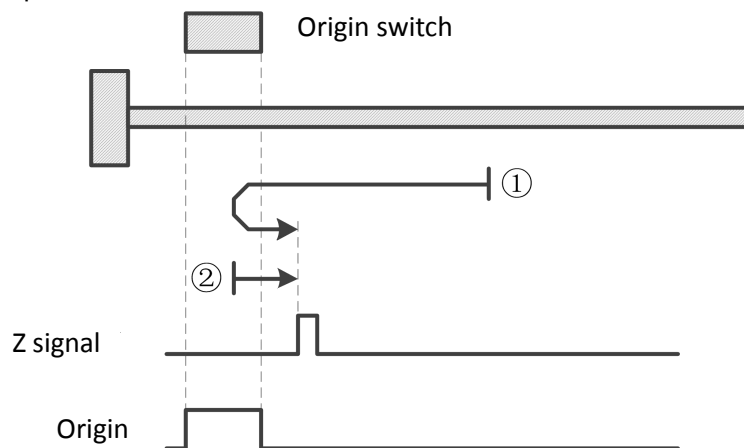

6098=6: Negative return-to-origin mode of reference origin switch and Z-phase signal

Situation 1: When starting the zero return, the origin signal is invalid, and the axis begins to return to zero in the negative direction at high speed. When encountering the rising edge of the origin, the motor decelerates and runs at low speed. The position when encountering the first Z pulse is the origin position.

Situation 2: When starting the zero return, the origin signal is valid. The axis starts to return to zero at a low speed in the positive direction. When it encounters the falling edge of the origin, it decelerates and runs in the negative direction at a low speed. When it encounters the first Z after the origin signal The position of the pulse is the origin position.

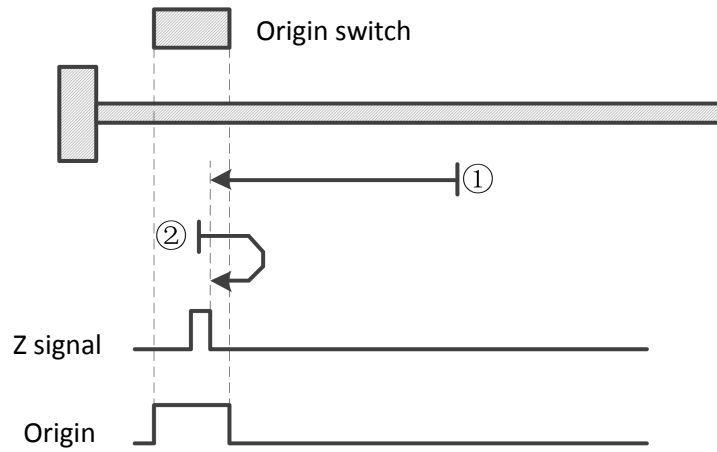

6098=7: Reference origin switch, positive limit and Z-phase signal return-to-origin mode 1

Situation 1: When starting the zero return, the origin signal is invalid, and the axis begins to return to zero at high speed in the positive direction. When encountering the rising edge of the origin, the motor decelerates and runs in the negative direction at low speed. When encountering the falling edge of the origin, the motor The position of one Z pulse is the origin position.

Situation 2: When the zero return is started, the origin signal is valid, and the axis begins to return to zero in the negative direction at a low speed. When it encounters the falling edge of the origin, the position of the first Z pulse is the origin position.

Situation 3: When the zero return is started, the origin signal is invalid, and the axis starts to return to zero at high speed in the positive direction. When encountering the rising edge of the positive limit, the motor decelerates and runs in the negative direction at high speed. When encountering the rising edge of the origin, the motor starts to decelerate and run at low speed. When encountering the falling edge of the origin, the position of the first Z pulse is the origin position.

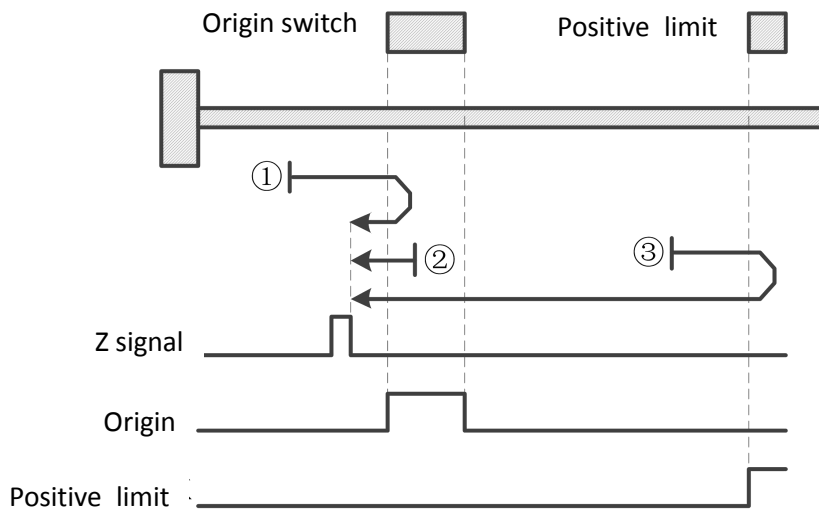

6098=8: Reference origin switch, positive limit and return-to-origin mode 2 of Z-phase signal

Situation 1: When the zero return is started, the origin signal is invalid, and the axis starts to return to zero at high speed in the positive direction. When encountering the rising edge of the origin, the motor decelerates and runs in the negative direction at low speed. When it encounters the falling edge of the origin, it decelerates again. Reverse direction, and then run in the forward direction at low speed. When encountering the rising edge of the origin, the position to the first Z pulse is the origin position.

Situation 2: When the zero return is started, the origin signal is valid, and the axis starts to return to zero at a low speed in the negative direction. When it encounters the falling edge of the origin, it decelerates and runs in the positive direction at a low speed. When it encounters the first rising edge of the origin, The position of the Z pulse is the origin position.

Situation 3: When the zero return is started, the origin signal is invalid, and the axis starts to return to zero at high speed in the positive direction. When encountering the rising edge of the positive limit, the motor decelerates and runs in the negative direction at high speed. When encountering the rising edge of the origin, the motor starts to run at low speed. When it encounters the falling edge of the origin, the motor

decelerates and reverses and runs toward the square at low speed. When it encounters the rising edge of the origin, the position of the first Z pulse is the origin position.

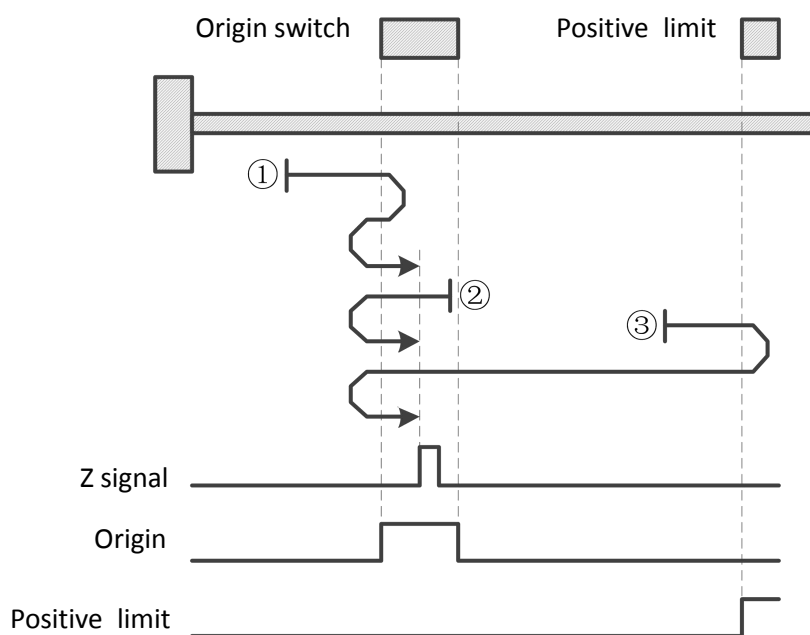

6098=9: Reference origin switch, positive limit and return-to-origin mode 3 of Z-phase signal

Situation 1: When starting the zero return, the origin signal is invalid, and the axis starts to return to zero in the forward direction at high speed. When encountering the rising edge of the origin, the motor decelerates and runs forward at low speed. After encountering the falling edge of the origin, the motor reverses and runs at low speed. Running in the negative direction, the position of the first Z pulse after encountering the rising edge of the origin is the origin position.

Situation 2: When the zero return starts, the origin signal is valid, and the axis starts to return to zero at a low speed in the positive direction. When encountering the falling edge of the origin, the motor decelerates and runs in the negative direction at low speed. After encountering the first rising edge of the origin, The position of the first Z pulse is the origin position.

Situation 3: When starting the zero return, the origin signal is invalid. The axis starts to return to zero at high speed in the positive direction. When encountering the rising edge of the positive limit, the motor decelerates and runs in the negative direction at high speed. After encountering the rising edge of the origin, the motor The deceleration reverse direction moves in the forward direction at a low speed. After encountering the falling edge of the origin, it reverses and then moves in the negative direction at a low speed. The position of the first Z pulse after encountering the rising edge of the origin is the origin position.

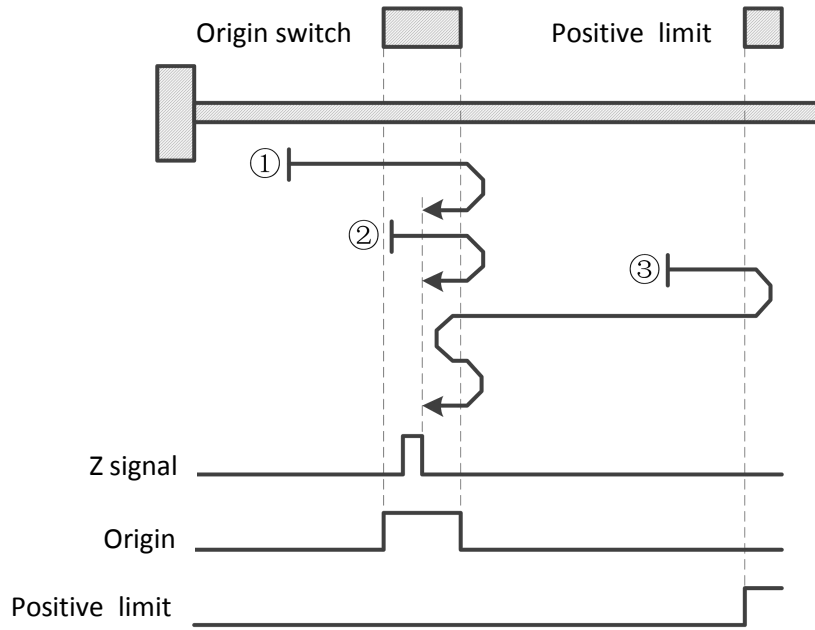

6098=10: Reference origin switch, positive limit and Z-phase signal return-to-origin mode 4

Situation 1: The origin signal is invalid when starting the zero return. The axis starts to return to zero in the forward direction at high speed. When encountering the rising edge of the origin, the motor decelerates and runs at low speed. When encountering the falling edge of the origin, the first Z pulse. The position is the origin position.

Situation 2: When the origin signal is valid when starting the zero return, the axis starts to return to zero at a low speed in the forward direction. The position of the first Z pulse when encountering the falling edge of the origin is the origin position.

Situation 3: The origin signal is invalid when starting to return to zero. The axis starts to return to zero in the positive direction at high speed. When encountering the rising edge of the positive limit, the motor decelerates and runs in the negative direction at high speed. When encountering the rising edge of the origin opening, the motor decelerates and runs in the forward direction at low speed. When it encounters the falling edge of the origin, the position of the first Z pulse is the origin position.

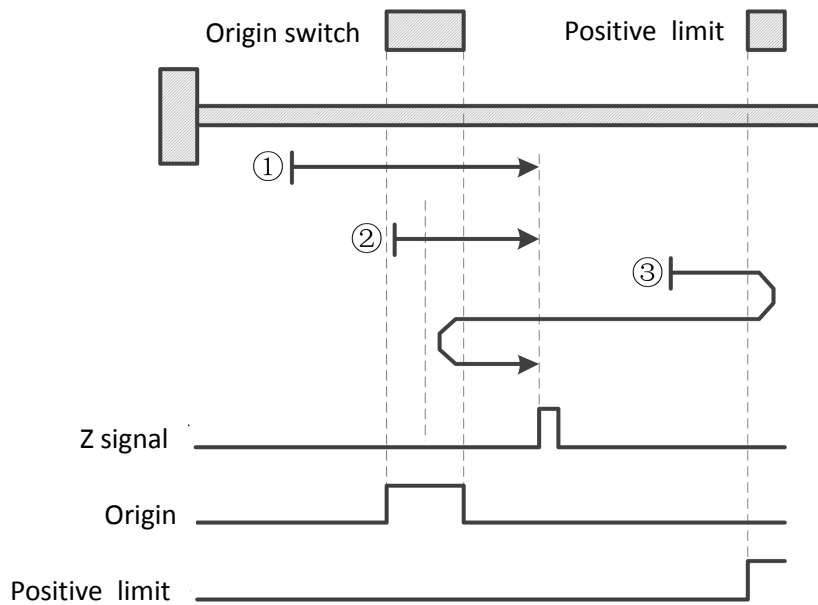

6098=11: Reference origin switch, negative limit and Z-phase signal return-to-origin mode 1

Situation 1: When starting the zero return, the origin signal is invalid. The axis starts to return to zero at high speed in the negative direction. When encountering the rising edge of the origin, the motor decelerates and runs in the forward direction at low speed. When encountering the falling edge of the origin, the motor The position of one Z pulse is the origin position.

Situation 2: When the origin signal is valid when starting the zero return, the axis starts to return to zero at a low speed in the forward direction. The position of the first Z pulse after encountering the falling edge of the origin is the origin position.

Situation 3: When starting the zero return, the origin signal is invalid, and the axis starts to return to zero at high speed in the negative direction. When it encounters the rising edge of the negative limit, the motor decelerates and runs in the positive direction at high speed. When it encounters the rising edge of the origin, the motor decelerates and runs at low speed. When encountering the falling edge of the origin, the position of the first Z pulse is the origin position.

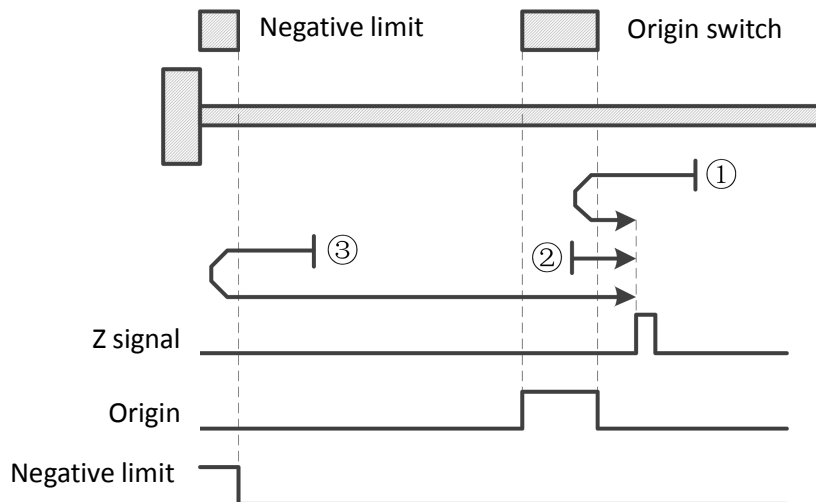
**6098=12: Reference origin switch, negative limit and return-to-origin mode 2 of Z-phase signal**

Situation 1: When starting the zero return, the origin signal is invalid, and the axis starts to return to zero at high speed in the negative direction. When encountering the rising edge of the origin, the motor decelerates and runs in the forward direction at low speed. When encountering the falling edge of the origin, the motor The deceleration reverse direction runs in the negative direction at low speed. When encountering the rising edge of the origin, the position of the first Z pulse is the origin position.

Situation 2: When starting the zero return, the origin signal is valid, and the axis starts to return to zero at a low speed in the positive direction. When encountering the falling edge of the origin, the motor decelerates and runs in the negative direction at a low speed. When it encounters the rising edge of the origin, the The position of one Z pulse is the origin position.

Situation 3: When starting the zero return, the origin signal is invalid, and the axis starts to return to zero at high speed in the negative direction. When encountering the rising edge of the negative limit, the motor decelerates and moves in the positive direction at high speed. When encountering the rising edge of the origin, the motor decelerates and runs at low speed. When it encounters the falling edge of the origin, the motor decelerates and runs in the negative direction at low speed. When it encounters the rising edge of the origin, the position of the first Z pulse is the origin position.

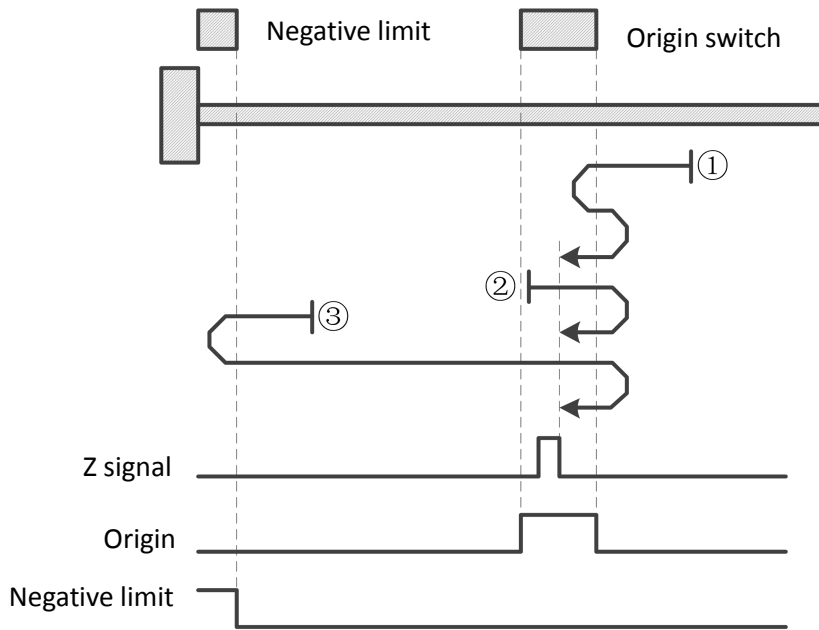

6098=13: Reference origin switch, negative limit and return-to-origin mode 3 of Z-phase signal

Situation 1: When starting the zero return, the origin signal is invalid, and the axis starts to return to zero at high speed in the negative direction. When encountering the rising edge of the origin, the motor decelerates and runs at low speed. When encountering the falling edge of the origin, the motor decelerates and reverses to low speed. Running in the forward direction, the position of the first Z pulse after encountering the rising edge of the origin is the origin position.

Situation 2: When the zero return starts, the origin signal is valid, and the axis starts to return to zero at a low speed in the negative direction. When encountering the falling edge of the origin, the motor decelerates and runs in the forward direction at low speed. When it encounters the rising edge of the origin, the The position of one Z pulse is the origin position.

Situation 3: When starting the zero return, the origin signal is invalid, and the axis starts to return to zero at high speed in the negative direction. When it encounters the rising edge of the negative limit, the motor decelerates and runs in the positive direction at high speed. When it encounters the rising edge of the origin, , the motor decelerates and runs in the negative direction at low speed. When it encounters the falling edge of the origin, the motor decelerates and runs in the forward direction at low speed. When it encounters the rising edge of the origin, the position of the first Z pulse is the origin position.

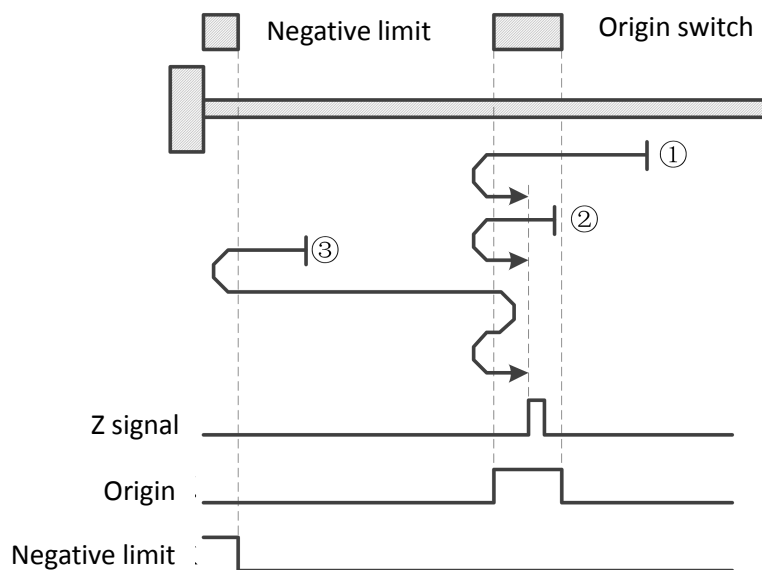

6098=14: Reference origin switch, negative limit and return-to-origin mode 4 of Z-phase signal

Situation 1: The origin signal is invalid when starting to return to zero. The axis starts to return to zero in the negative direction at high speed. When encountering the rising edge of the origin, the motor decelerates and runs at

low speed. When encountering the falling edge of the origin, the first Z pulse The position is the origin position.

Situation 2: When the origin signal is valid when the zero return is started, the axis starts to return to zero at a low speed in the negative direction. The position of the first Z pulse after encountering the falling edge of the origin is the origin position.

Situation 3: When starting the zero return, the origin signal is invalid, and the axis starts to return to zero at high speed in the negative direction. When it encounters the rising edge of the negative limit, the motor decelerates and runs in the positive direction at high speed. When it encounters the rising edge of the origin, the motor decelerates and runs in the negative direction at low speed. When it encounters the falling edge of the origin, the position of the first Z pulse is the origin position.

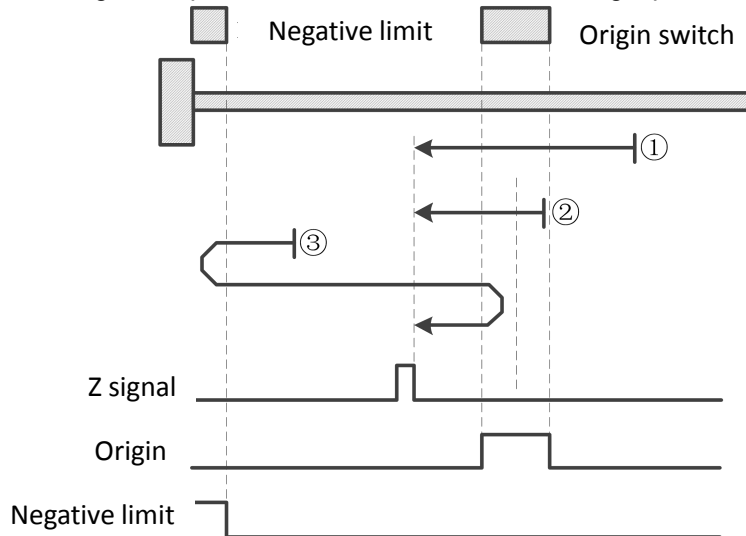

6098=17: Reference negative limit return-to-origin mode

Situation 1: The negative limit signal is invalid when starting to return to zero. The axis starts to return to zero at high speed in the negative direction. When encountering the rising edge of the negative limit, the motor decelerates and runs in the forward direction. When encountering the falling edge of the negative limit, the motor decelerates and runs in the forward direction. The position at time is the origin position.

Situation 2: When starting the zero return, the negative limit signal is valid, and the axis starts to return to zero at a low speed in the positive direction. The position when it encounters the negative limit falling edge is the origin position.

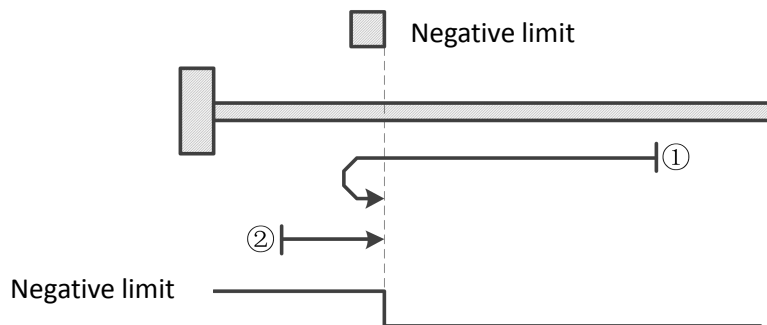

6098=18: Reference positive limit return-to-origin mode

Situation 1: The positive limit signal is invalid when starting to return to zero. The axis starts to return to zero in the positive direction at high speed. When encountering the rising edge of the positive limit, the motor decelerates and runs in the negative direction. When encountering the falling edge of the positive limit, the motor decelerates and runs in the negative direction. The position at time is the origin position.

Situation 2: When starting the zero return, the positive limit signal is valid, and the axis starts to return to zero in the negative direction at low speed. The position when it encounters the falling edge of the positive limit is the origin position.

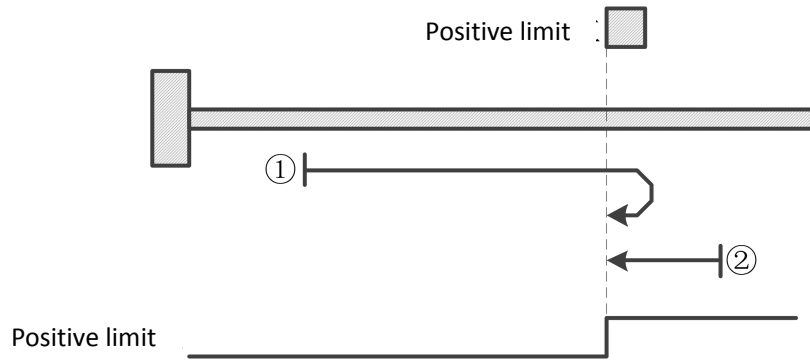

6098=19: Reference origin switch return-to-origin mode 1

Situation 1: The origin signal is invalid when starting to return to zero. The axis starts to return to zero in the positive direction at high speed. When encountering the rising edge of the origin, the motor decelerates and runs in the negative direction. The position when encountering the falling edge of the origin is the origin position.

Situation 2: When the origin signal is valid when starting the zero return, the axis starts to return to zero at a low speed in the negative direction. The position when it encounters the falling edge of the origin is the origin position.

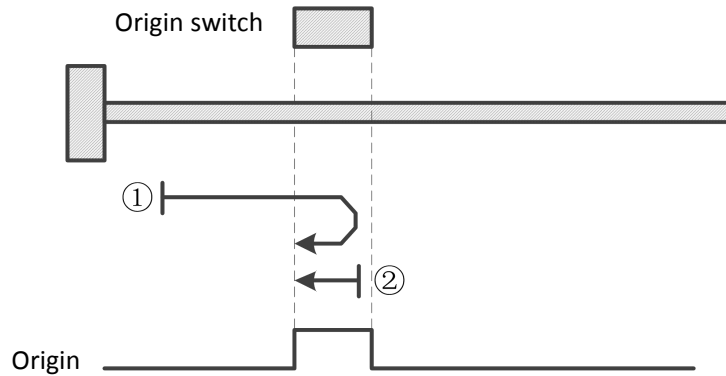

6098=20: Reference origin switch return-to-origin mode 2

Situation 1: The origin signal is invalid when the zero return is started. The axis starts to return to zero at a low speed in the forward direction. The position when it encounters the rising edge of the origin is the origin position.

Situation 2: When the origin signal is valid when the zero return is started, the axis starts to return to zero at a low speed in the negative direction. When encountering the falling edge of the origin, the motor decelerates and runs in the forward direction. When it encounters the rising edge of the origin, the position is the origin position.

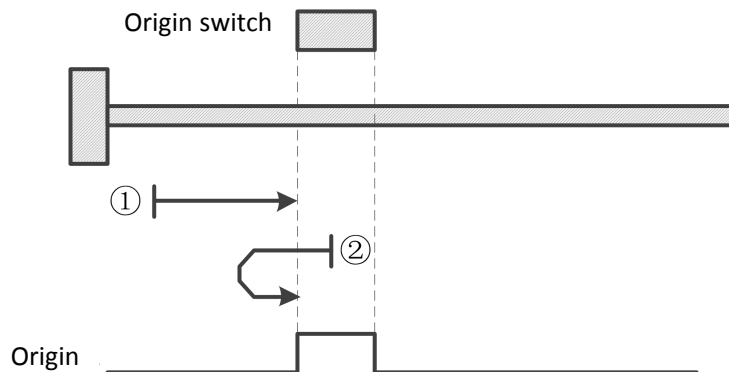

6098=21: Return to origin mode of reference origin switch

Situation 1: The origin signal is invalid when the zero return is started. The axis starts to return to zero at high speed in the negative direction. When it encounters the rising edge of the origin, the motor decelerates and runs in the forward direction. When it encounters the falling edge of the origin, the position is the origin position. .

Situation 2: When the origin signal is valid when the zero return is started, the axis starts to return to zero at a low speed in the forward direction. The position when it encounters the falling edge of the origin is the origin position.

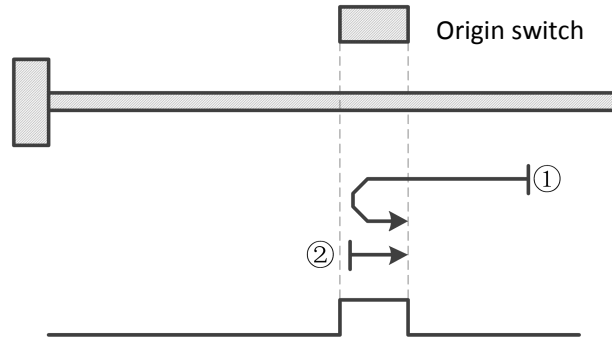
**6098=22: Reference origin switch return-to-origin mode**

Scenario 1: The origin signal is invalid when the zero return is started. The axis starts to return to zero at a low speed in the negative direction. The position when it encounters the rising edge of the origin is the origin position.

Situation 2: When the zero return is started, the origin signal is valid, and the axis starts to return to zero at a low speed in the positive direction. When it encounters the falling edge of the origin, the motor decelerates and runs in the negative direction. When it encounters the rising edge of the origin, the position is the origin position.

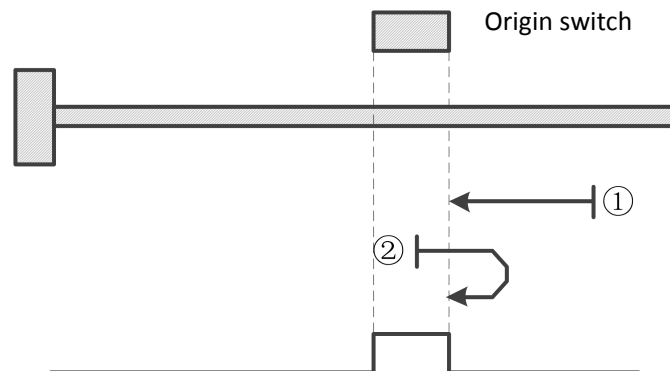
**6098=23: Reference origin switch and positive limit return-to-origin mode**

Situation 1: When starting the zero return, the origin signal is invalid. The axis starts to return to zero at high speed in the positive direction. When encountering the rising edge of the origin, the motor decelerates and runs in the negative direction at low speed. When it encounters the falling edge of the origin, the position is origin position.

Situation 2: When the zero return is started, the origin signal is valid, and the axis starts to return to zero at a low speed in the negative direction. When it encounters the falling edge of the origin, it is the origin position.

Situation 3: When starting the zero return, the origin signal is invalid. The axis starts to return to zero at high speed in the positive direction. When encountering the rising edge of the positive limit, the motor decelerates and runs in the negative direction at high speed. When encountering the rising edge of the origin, the motor decelerates and runs in the negative direction at low speed. The position when it encounters the falling edge of the origin is the origin position.

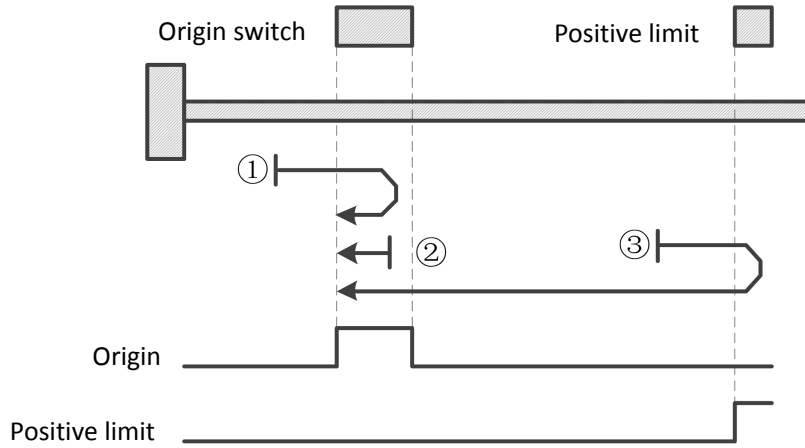

6098=24: Reference origin switch and positive limit return-to-origin mode

Situation 1: When starting the zero return, the origin signal is invalid. The axis starts to return to zero at high speed in the positive direction. When encountering the rising edge of the origin, the motor decelerates and runs in the negative direction at low speed. When encountering the falling edge of the origin, the motor The deceleration reverse direction runs in the forward direction at low speed. The position after encountering the rising edge of the origin is the origin position.

Situation 2: When the zero return starts, the origin signal is valid, and the axis starts to return to zero at a low speed in the negative direction. When encountering the falling edge of the origin, the motor decelerates and runs in the positive direction at low speed. When it encounters the rising edge of the origin, the position is origin position.

Situation 3: When starting the zero return, the origin signal is invalid. The axis starts to return to zero at high speed in the positive direction. When encountering the rising edge of the positive limit, the motor decelerates and runs in the negative direction at high speed. When encountering the rising edge of the origin, , the motor decelerates and runs at low speed. When it encounters the falling edge of the origin, the motor decelerates and runs in the forward direction at low speed. When it encounters the rising edge of the origin, the position is the origin position.

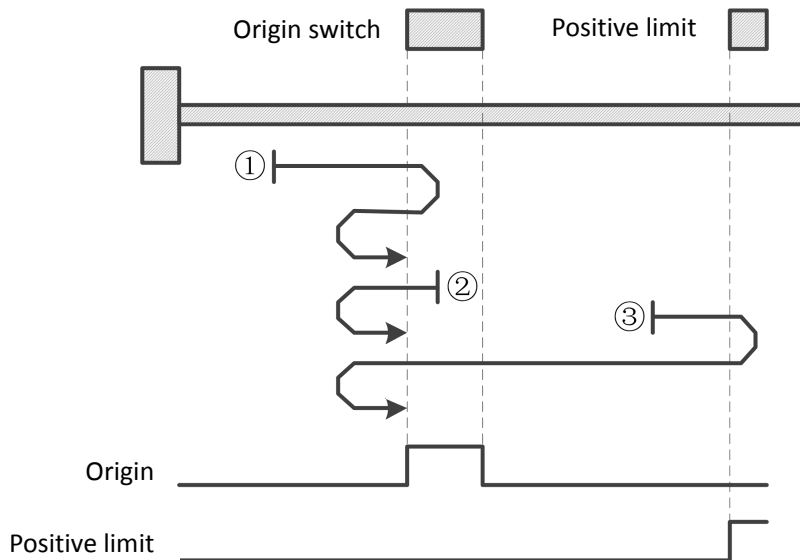

6098=25: Reference origin switch and positive limit return-to-origin mode

Situation 1: When starting the zero return, the origin signal is invalid, and the axis starts to return to zero in the forward direction at high speed. When encountering the rising edge of the origin, the motor decelerates and runs forward at low speed. After encountering the falling edge of the origin, the motor reverses and runs at low speed. Running in the negative direction, the position when encountering the rising edge of the origin is the origin position.

Situation 2: When the zero return is started, the origin signal is valid, and the axis starts to return to zero at a low speed in the positive direction. When encountering the falling edge of the origin, the motor decelerates and runs in the negative direction at low speed. The position where it encounters the rising edge of the origin is

the origin. Location.

Situation 3: When starting the zero return, the origin signal is invalid. The axis starts to return to zero at high speed in the positive direction. When encountering the rising edge of the positive limit, the motor decelerates and runs in the negative direction at high speed. After encountering the rising edge of the origin, the motor The deceleration reverse direction moves in the positive direction at a low speed. When it encounters the falling edge of the origin, it reverses and then moves in the negative direction at a low speed. The position when it encounters the rising edge of the origin is the origin position.

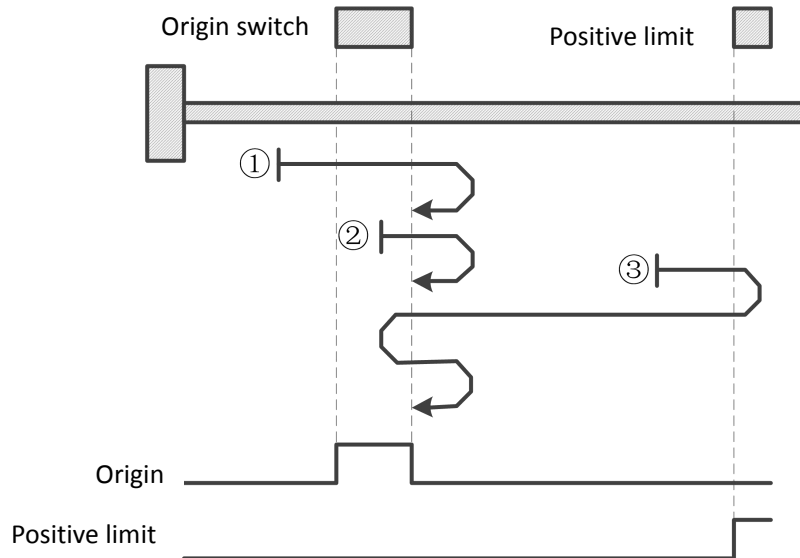

6098=26: Reference origin switch and positive limit return-to-origin mode

Situation 1: The origin signal is invalid when starting to return to zero. The axis starts to return to zero in the forward direction at high speed. When encountering the rising edge of the origin, the motor decelerates and runs at low speed. When encountering the falling edge of the origin, the position is the origin position.

Situation 2: When the origin signal is valid when the zero return is started, the axis starts to return to zero at a low speed in the forward direction. The position when it encounters the falling edge of the origin is the origin position.

Situation 3: The origin signal is invalid when starting to return to zero. The axis starts to return to zero in the positive direction at high speed. When encountering the rising edge of the positive limit, the motor decelerates and runs in the negative direction at high speed. When encountering the rising edge of the origin opening, When , the motor decelerates and runs in the forward direction at low speed. When it encounters the falling edge of the origin, the position is the origin position.

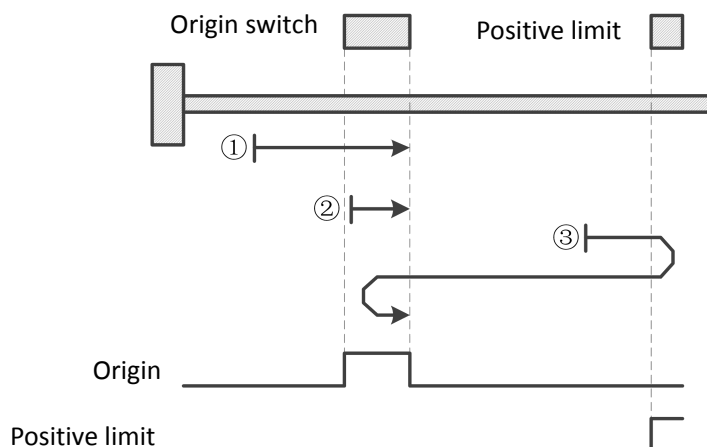

6098=27: Reference origin switch and negative limit return-to-origin mode

Situation 1: When starting to return to zero, the origin signal is invalid. The axis starts to return to zero at high speed in the negative direction. When encountering the rising edge of the origin, the motor decelerates and runs in the forward direction at low speed. When encountering the falling edge of the origin, the position is origin position.

Situation 2: When the origin signal is valid when starting the zero return, the axis starts to return to zero in the forward direction at a low speed. When it encounters the falling edge of the origin, it is the origin position.

Situation 3: When starting the zero return, the origin signal is invalid, and the axis starts to return to zero at high speed in the negative direction. When it encounters the rising edge of the negative limit, the motor decelerates and runs in the positive direction at high speed. When it encounters the rising edge of the origin, the motor decelerates and runs at low speed. When it encounters the falling edge of the origin, the position is the origin position.

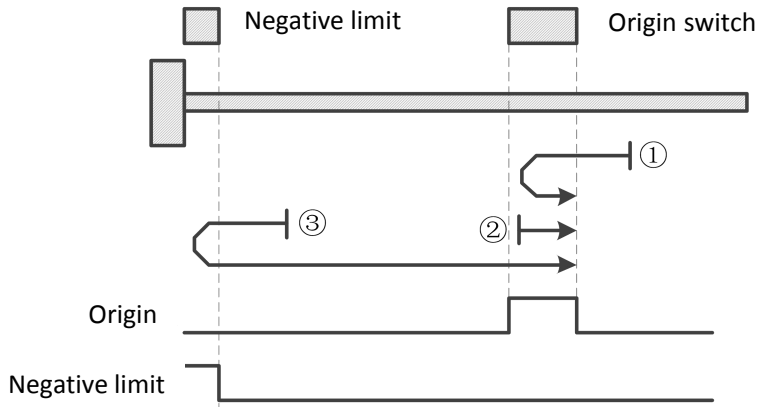

6098=28: Reference origin switch and negative limit return-to-origin mode

Situation 1: When starting the zero return, the origin signal is invalid, and the axis starts to return to zero at high speed in the negative direction. When encountering the rising edge of the origin, the motor decelerates and runs in the forward direction at low speed. When encountering the falling edge of the origin, the motor The deceleration reverse direction runs in the negative direction at low speed. When it encounters the rising edge of the origin, the position is the origin position.

Situation 2: When the origin signal is valid when starting the zero return, the axis starts to return to zero at a low speed in the positive direction. When encountering the falling edge of the origin, the motor decelerates and runs in the negative direction at a low speed. When it reaches the rising edge of the origin, it is the origin position.

Situation 3: When starting the zero return, the origin signal is invalid, and the axis starts to return to zero at high speed in the negative direction. When encountering the rising edge of the negative limit, the motor decelerates and moves in the positive direction at high speed. When encountering the rising edge of the origin, the motor decelerates and runs at low speed. When it encounters the falling edge of the origin, the motor decelerates and runs in the negative direction at low speed. When it encounters the rising edge of the origin, it is the origin position.

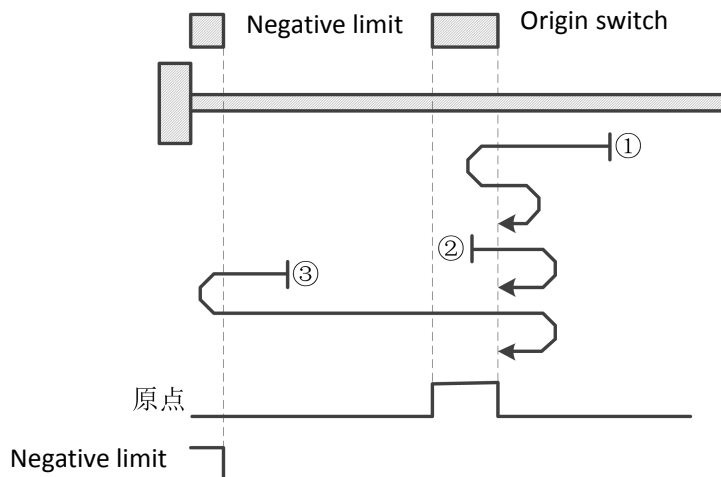

6098=29: Reference origin switch and negative limit return-to-origin mode

Situation 1: When starting the zero return, the origin signal is invalid, and the axis starts to return to zero at high speed in the negative direction. When encountering the rising edge of the origin, the motor decelerates and runs at low speed. When encountering the falling edge of the origin, the motor decelerates and reverses to low speed. Running in the forward direction, the position when encountering the rising edge of the origin is the origin position.

Situation 2: When the zero return starts, the origin signal is valid, and the axis starts to return to zero at a low speed in the negative direction. When encountering the falling edge of the origin, the motor decelerates and runs in the positive direction at low speed. When it encounters the rising edge of the origin, the position is origin position.

Situation 3: When starting the zero return, the origin signal is invalid, and the axis starts to return to zero at high speed in the negative direction. When it encounters the rising edge of the negative limit, the motor decelerates and runs in the positive direction at high speed. When it encounters the rising edge of the origin, the motor decelerates and runs in the negative direction at low speed. When it encounters the falling edge of the origin, the motor decelerates and runs in the forward direction at low speed. When it encounters the rising edge of the origin, the position is the origin position.

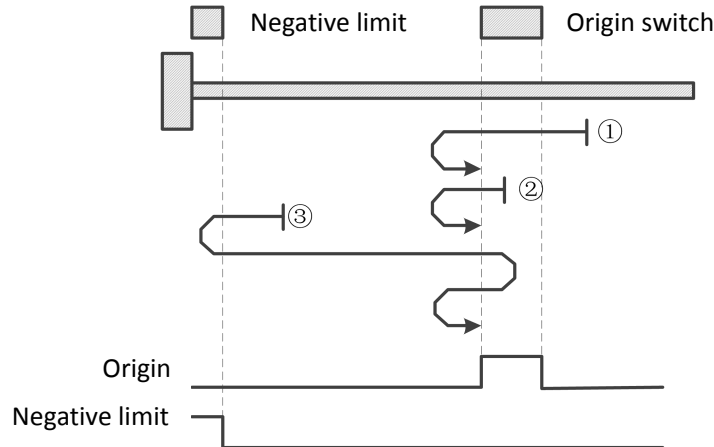

6098=30: Reference origin switch and negative limit return-to-origin mode

Situation 1: When starting the zero return, the origin signal is invalid, and the axis starts to return to zero at high speed in the negative direction. When encountering the rising edge of the origin, the motor decelerates and runs at low speed. When encountering the falling edge of the origin, the position is the origin position.

Situation 2: When the zero return is started, the origin signal is valid, and the axis starts to return to zero at a low speed in the negative direction. When it encounters the falling edge of the origin, it is the origin position.

Situation 3: When starting the zero return, the origin signal is invalid, and the axis starts to return to zero at high speed in the negative direction. When it encounters the rising edge of the negative limit, the motor decelerates and runs in the positive direction at high speed. When it encounters the rising edge of the origin, the motor decelerates and runs in the negative direction at low speed. When it encounters the falling edge of the origin, the position is the origin position.

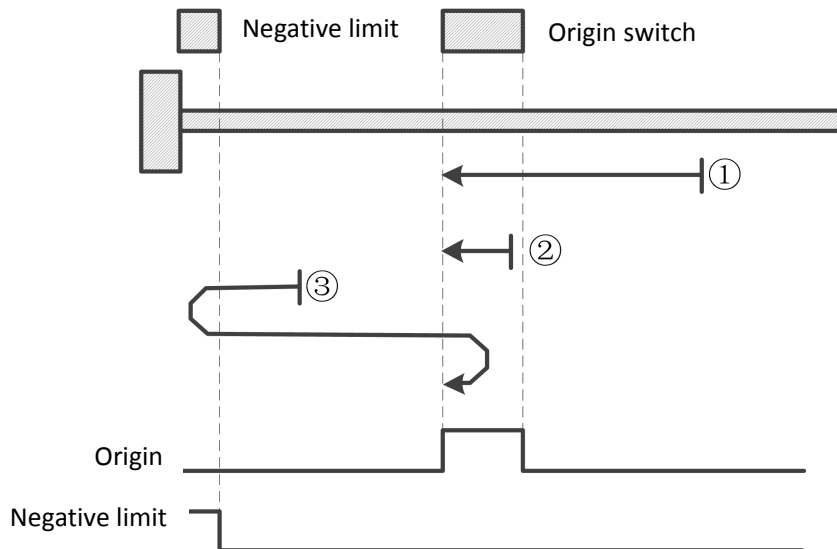

6098=33/34: Reference Z signal return-to-origin mode

Zero return method 33: The axis starts to return to zero in the negative direction at low speed. The position of the first Z pulse encountered is the origin position.

Zero return mode 34: The axis starts to return to zero in the forward direction at low speed, and the position of the first Z pulse encountered is the origin position.

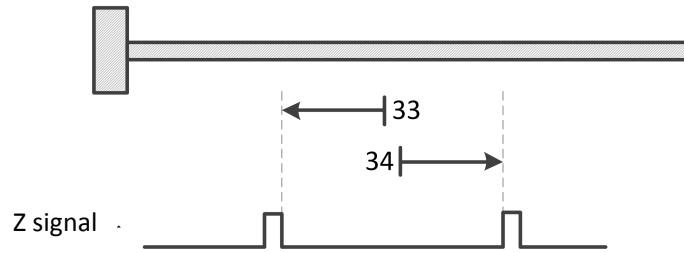

6098=35: Take the current position as the origin

Taking the current position as the mechanical origin, after triggering the origin return (6040 control word: 0x0F→0x1F):

1. When 60E6=0, set the current position 6064 to the value of the origin offset 606C;
2. When 60E6=1, the current position 6064 is superimposed on the original position offset 606C.